



LEISURE MARINE ROPES

2025 | ENG

Upgrade Your Lines



KAYA COMPANIES

www.kayacompanies.com

Kaya Companies;

A leader in its field today, Kaya Group began business in the 1980's as Kaya Construction. Kaya Group concentrates its knowledge and experience in four main areas of activity; the production of technical ropes, industrial work safety and work at height, health and safety at work training and consulting services. Since being fully aware of the dimension of social responsibility attached to the sector, the company obtains national and international certificates for all products that are developed and manufactured. By providing education and consultation services concerning the correct use of its products, the Kaya Group has gained the knowledge, experience and level of competence that have given the company the confidence and resources to be able to make new advances from a sound base. With its 40+ year experience, the Kaya Group is the largest organization in the sector. In 2010, with new products, services and investments, the company is firmly on the path towards becoming an important brand in the international market.

Our Vision;

To make Kaya the undisputed world's strongest, most prestigious and trusted brand in its sector.

Mission Statement;

Our mission is to conduct research and development based on accurate analysis of needs in the sector and thereby develop new products; to employ modern machinery and a competent workforce in the manufacture of world-class, high quality goods; to provide training and consulting services to create knowledgeable workers and managers and help establish a culture of work safety in Turkey; and to provide complete solutions via our integrated services.

Company Philosophy;

Based on the value we place on human life, our goal is to design products that will safeguard human life on the job, to manufacture such products and to raise awareness about work safety by training workers and managers and providing consultation services in this regard.

KAYA SAFETY | KAYA ROPES | KAYA ARCHITECTURE | KAYA TRAINING | KAYA ADVENTURE | KAYA SCAFFOLDING
KAYA CONSTRUCTION | KAYA RESCUE | KAYA DEFENCE | KAYA SECURITY | KAYA SPORT | KAYA LIFTING | KAYA NATURAL



Index:

Page	Content
01	Kaya Companies Activities
05	All Products
06	Racing Lines
26	Cruising Lines
38	Dinghy Lines
48	Mooring Lines
76	Water Sports Lines
80	Sailmaker Lines
86	Lifting Equipment - Slings
88	Accessories
91	Technical Appendix
92	Our Materials
93	Our Treatments
94	Choose Your Core
95	Choose Your Cover
96	Type of Splicing
98	Fiber Facts
100	Users' Manual
101	Formulae
102	Standards
103	Quality - Testing
104	Partners

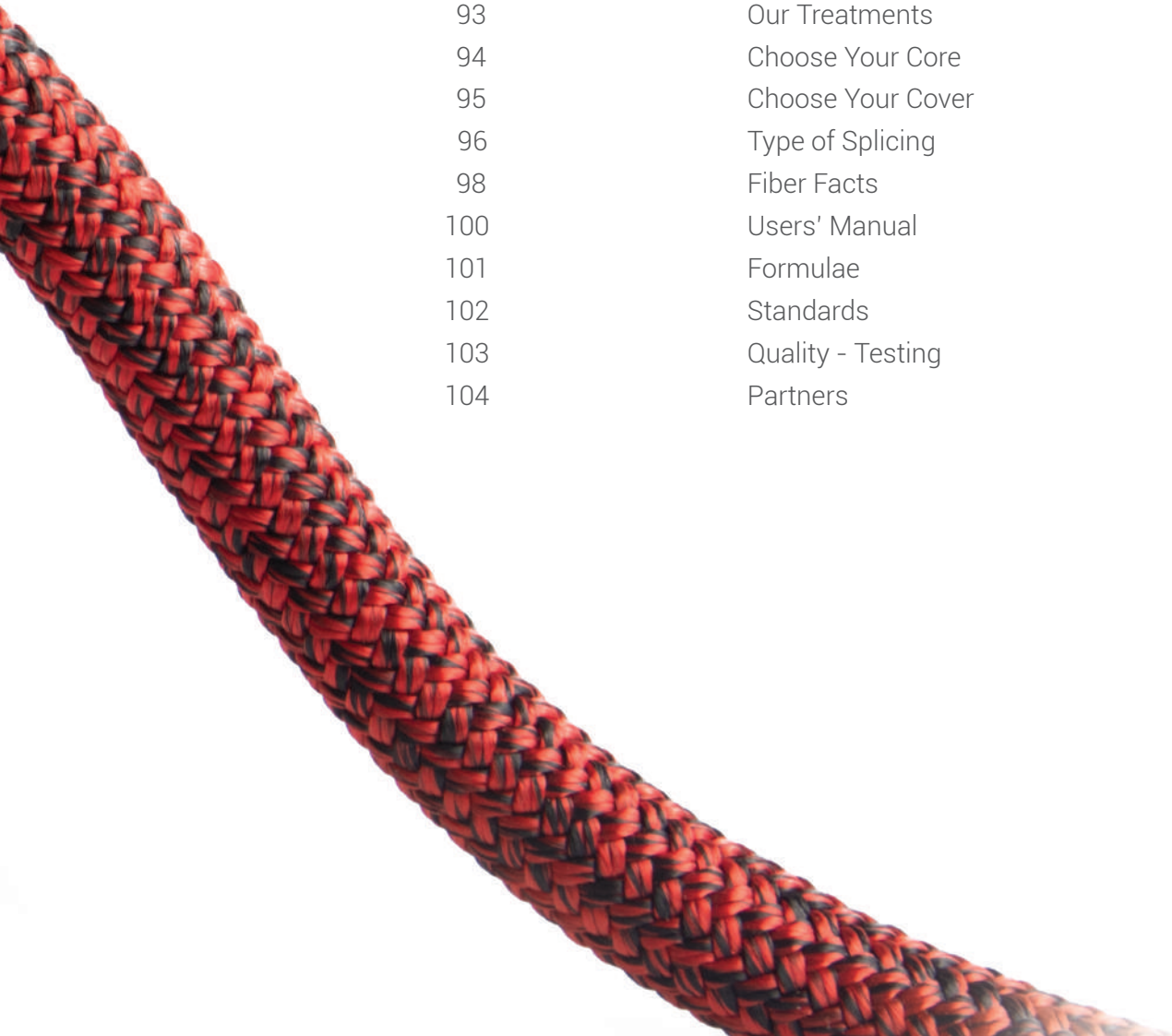



06



RACING
LINES

CRUISING
LINES



26

38



DINGHY
LINES

MOORING
LINES



48

76



WATER
SPORTS
LINES

SAILMAKER
LINES



80

RACING LINES



GP ROCK D® MIX TP

APPLICATIONS

Main Halyard
Genoa Halyard
Spi Halyard
Reefing Lines
Main Sheet
Genoa Sheet
Spi Sheet
Spi Guys

See Page 25

BENEFITS / FEATURES

Good Grip on Winches
Very Good Performance in Jammers
Excellent Breaking Load (SK99)
Very Good Heat Resistance
Low Stretch
Easy to Splice



SPECIFICATIONS

Material	: Cover: %50 Technora® Fiber %50 HT Polyester Fiber Core: Coated Dyneema® SK 78/99 Fiber
Specific Gravity	: 0,99-1,20 kg/dm³
Construction	: Cover: 24-32 Plaited Core: 12 Plaited
UV Resistance	: Sufficient
Chemical Resistance	: Excellent
Melting Point	: 147-256°C
Critical Temperature	: 65°C
Working Stretch	: <1,5%
Fiber Water Absorption	: Approx. %1-2
Wet Abrasion	: Excellent
Dry Abrasion	: Excellent
Standard	: -
Length	: 100-200 m Plastic/Wooden Spool or Coil

Other Colours & Larger Diameters Upon Request

DIA (mm)	Weight (kg/100m)	B.Load (kgf) TP78	B.Load (kgf) TP99	DIA (inch)	Weight (lbs/100ft)	B.Load (lbs) TP78	B.Load (lbs) TP99
8	4,85	5.000	5.975	5/16"	3,26	11.000	13.145
10	7,10	7.500	8.960	3/8"	4,77	16.500	19.712
12	9,95	10.000	11.950	1/2"	6,69	22.000	26.290
14	13,25	13.880	16.585	9/16"	8,90	30.536	36.487
16	18,00	16.660	19.905	5/8"	12,10	36.652	43.791
18	22,25	21.660	25.880	3/4"	14,95	47.652	56.936
20	27,95	25.550	30.530	13/16"	18,78	56.210	67.166
22	30,30	27.490	32.850	7/8"	20,36	60.478	72.270
24	34,80	31.660	37.830	1"	23,39	69.652	83.226

*Unspliced Break Load (All Tests are in Accordance with ISO 2307)



Technora



GP ROCK D® MIX TP ▲ RACING LINES



GP ROCK D® MIX VP

APPLICATIONS

Main Sheet
 Genoa Sheet
 Spi Sheet
 Spi Guys
 Gennaker Tack-Line
 Backstays

See Page 25

BENEFITS / FEATURES

Excellent Grip on Winches
 Excellent Breaking Load (SK99)
 Good Heat Resistance
 Low Stretch
 Easy to Splice



SPECIFICATIONS

Material	:	Cover: %50 Vectran® Fiber %50 HT Polyester Fiber Core: Coated Dyneema® SK 78/99 Fiber
Specific Gravity	:	0,99-1,20 kg/dm³
Construction	:	Cover: 24-32 Plaited Core: 12 Plaited
UV Resistance	:	Poor
Chemical Resistance	:	Excellent
Melting Point	:	147-256°C
Critical Temperature	:	65°C
Working Stretch	:	<1,5%
Fiber Water Absorption	:	Approx. %0-1
Wet Abrasion	:	Excellent
Dry Abrasion	:	Excellent
Standard	:	-
Length	:	100-200 m Plastic/Wooden Spool or Coil

Other Colours & Larger Diameters Upon Request

DIA (mm)	Weight (kg/100m)	B.Load (kgf) VP78	B.Load (kgf) VP99	DIA (inch)	Weight (lbs/100ft)	B.Load (lbs) VP78	B.Load (lbs) VP99
8	4,85	5.000	5.975	5/16"	3,26	11.000	13.145
10	7,10	7.500	8.960	3/8"	4,77	16.500	19.712
12	9,95	10.000	11.950	1/2"	6,69	22.000	26.290
14	13,25	13.880	16.585	9/16"	8,90	30.536	36.487
16	18,00	16.660	19.905	5/8"	12,10	36.652	43.791
18	22,25	21.660	25.880	3/4"	14,95	47.652	56.936
20	27,95	25.550	30.530	13/16"	18,78	56.210	67.166
22	30,30	27.490	32.850	7/8"	20,36	60.478	72.270
24	34,80	31.660	37.830	1"	23,39	69.652	83.226

*Unspliced Break Load (All Tests are in Accordance with ISO 2307)



GP ROCK D® MIX AP

APPLICATIONS

Main Sheet
Genoa Sheet
Spi Sheet
Spi Guys
Gennaker Tack-Line
Backstays

See Page 25

BENEFITS / FEATURES

Good Grip on Winches
Excellent Performance in Jammers
Excellent Breaking Load (SK99)
Very Good Heat Resistance
Low Stretch
Easy to Splice



SPECIFICATIONS

Material	:	Cover: %50 Twaron® Fiber %50 HT Polyester Fiber Core: Coated Dyneema® SK 78/99 Fiber
Specific Gravity	:	0,99-1,20 kg/dm³
Construction	:	Cover: 24-32 Plaited Core: 12 Plaited
UV Resistance	:	Poor
Chemical Resistance	:	Excellent
Melting Point	:	147-256°C
Critical Temperature	:	65°C
Working Stretch	:	<1,5%
Fiber Water Absorption	:	Approx. %1-2
Wet Abrasion	:	Excellent
Dry Abrasion	:	Excellent
Standard	:	-
Length	:	100-200 m Plastic/Wooden Spool or Coil

Other Colours & Larger Diameters Upon Request

DIA (mm)	Weight (kg/100m)	B.Load (kgf) AP78	B.Load (kgf) AP99	DIA (inch)	Weight (lbs/100ft)	B.Load (lbs) AP78	B.Load (lbs) AP99
8	4,80	5.000	5.975	5/16"	3,23	11.000	13.145
10	7,00	7.500	8.960	3/8"	4,70	16.500	19.712
12	9,85	10.000	11.950	1/2"	6,62	22.000	26.290
14	13,10	13.880	16.585	9/16"	8,80	30.536	36.487
16	17,75	16.660	19.905	5/8"	11,93	36.652	43.791
18	22,00	21.660	25.880	3/4"	14,78	47.652	56.936
20	27,55	25.550	30.530	13/16"	18,51	56.210	67.166
22	29,90	27.490	32.850	7/8"	20,09	60.478	72.270
24	34,30	31.660	37.830	1"	23,05	69.652	83.226

*Unspliced Break Load (All Tests are in Accordance with ISO 2307)



GP ROCK D® MIX AP ▲ RACING LINES





GP ROCK D® MIX

APPLICATIONS

- Main Halyard
- Genoa Halyard
- Spi Halyard
- Reefing Lines
- Main Sheet
- Genoa Sheet
- Spi Sheet
- Spi Guys

See Page 25

BENEFITS / FEATURES

- Good Performance in Jammers
- Low Stretch
- Easy to Splice



SPECIFICATIONS

- Material : Cover: HT Polyester Fiber
Core: Coated Dyneema® SK 78/99 Fiber
- Specific Gravity : 0,99-1,20 kg/dm³
- Construction : Cover: 24-32 Plaited
Core: 12 Plaited
- UV Resistance : Excellent
- Chemical Resistance : Good
- Melting Point : 147-256°C
- Critical Temperature : 65°C
- Working Stretch : <1,5%
- Fiber Water Absorption : Approx. %0-1
- Wet Abrasion : Good
- Dry Abrasion : Good
- Standard : -
- Length : 100-200 m Plastic/Wooden Spool or Coil

Other Colours & Larger Diameters Upon Request

DIA (mm)	Weight (kg/100m)	B.Load (kgf) SK78	B.Load (kgf) SK99	DIA (inch)	Weight (lbs/100ft)	B.Load (lbs) SK78	B.Load (lbs) SK99
8	5,15	5.000	5.975	5/16"	3,46	11.000	13.145
10	7,05	7.500	8.960	3/8"	4,74	16.500	19.712
12	9,85	10.000	11.950	1/2"	6,62	22.000	26.290
14	13,10	13.880	16.585	9/16"	8,80	30.536	36.487
16	17,30	16.660	19.905	5/8"	11,63	36.652	43.791
18	21,50	21.660	25.880	3/4"	14,45	47.652	56.936
20	27,10	25.550	30.530	13/16"	18,21	56.210	67.166
22	29,45	27.490	32.850	7/8"	19,79	60.478	72.270
24	34,35	31.660	37.830	1"	23,08	69.652	83.226

*Unspliced Break Load (All Tests are in Accordance with ISO 2307)



GP ROCK D® MIX DP

APPLICATIONS

Main Halyard
Genoa Halyard
Spi Halyard
Reefing Lines
Spi Pole Uphaul
Spi Pole Foreguy
Gennaker Tack-Line
Roller Reefing Line

See Page 25

BENEFITS / FEATURES

Good Performance in Jammers
Excellent Breaking Load (SK99)
Excellent Abrasion Resistance
Low Stretch
Easy to Splice



SPECIFICATIONS

Material	:	Cover: %50 Dyneema® SK 78 Fiber %50 HT Polyester Fiber Core: Coated Dyneema® SK 78/99 Fiber
Specific Gravity	:	0,99-1,20 kg/dm³
Construction	:	Cover: 24-32 Plaited Core: 12 Plaited
UV Resistance	:	Excellent
Chemical Resistance	:	Good
Melting Point	:	147°C
Critical Temperature	:	65°C
Working Stretch	:	<1,5%
Fiber Water Absorption	:	Approx. %0-1
Wet Abrasion	:	Excellent
Dry Abrasion	:	Excellent
Standard	:	-
Length	:	100-200 m Plastic/Wooden Spool or Coil

Other Colours & Larger Diameters Upon Request

DIA (mm)	Weight (kg/100m)	B.Load (kgf) DP78	B.Load (kgf) DP99	DIA (inch)	Weight (lbs/100ft)	B.Load (lbs) DP78	B.Load (lbs) DP99
8	4,95	5.000	5.975	5/16"	3,33	11.000	13.145
10	6,65	7.500	8.960	3/8"	4,47	16.500	19.712
12	9,50	10.000	11.950	1/2"	6,38	22.000	26.290
14	12,65	13.880	16.585	9/16"	8,50	30.536	36.487
16	16,70	16.660	19.905	5/8"	11,22	36.652	43.791
18	20,55	21.660	25.880	3/4"	13,81	47.652	56.936
20	26,20	25.550	30.530	13/16"	17,61	56.210	67.166
22	28,15	27.490	32.850	7/8"	18,92	60.478	72.270
24	32,75	31.660	37.830	1"	22,01	69.652	83.226

*Unspliced Break Load (All Tests are in Accordance with ISO 2307)



GP ROCK D® MIX DP ▲ RACING LINES





GP ROCK V®

APPLICATIONS

- Main Halyard
- Genoa Halyard
- Main Sheet
- Spi Guys
- Cunningham
- Main Outhaul

See Page 25

BENEFITS / FEATURES

- Good Performance in Jammers
- High Breaking Load
- Extremely Low Stretch
- Easy to Splice



SPECIFICATIONS

- Material : Cover: HT Polyester Fiber
Core: Coated Vectran® Fiber
- Specific Gravity : Approx. 1,38 kg/dm³
- Construction : Cover: 24-32 Plaited
Core: 12 Plaited
- UV Resistance : Poor
- Chemical Resistance : Good
- Melting Point : 256°C
- Critical Temperature : 170°C
- Working Stretch : <1%
- Fiber Water Absorption : Approx. %1-2
- Wet Abrasion : Good
- Dry Abrasion : Good
- Standard : -
- Length : 100-200 m Plastic/Wooden Spool or Coil

Other Colours & Larger Diameters Upon Request

DIA (mm)	Weight (kg/100m)	B.Load (kgf)	DIA (inch)	Weight (lbs/100ft)	B.Load (lbs)
8	6,05	2.800	5/16"	4,07	6.160
10	8,65	4.200	3/8"	5,81	9.240
12	11,40	6.100	1/2"	7,66	13.420
14	15,95	9.300	9/16"	10,72	20.460
16	22,80	12.100	5/8"	15,32	26.620
18	27,35	15.400	3/4"	18,38	33.880
20	34,20	18.600	13/16"	22,98	40.920

*Unspliced Break Load (All Tests are in Accordance with ISO 2307)



Vectran™



APPLICATIONS

Spi Pole Uphaul
Spi Pole Foreguy
Vang
Cunningham
Main Outhaul

See Page 25

BENEFITS / FEATURES

No Creep Under Constant Loads
High Breaking Load
Extremely Low Stretch
Ideal for Steering System
Easy to Splice
Perfect for Static Application
Pu Coating for Better Abrasion Resistance



SPECIFICATIONS

Material	: Coated Vectran® Fiber
Specific Gravity	: 1,40 kg/dm³
Construction	: 12 Strand Braided
UV Resistance	: Poor
Chemical Resistance	: Excellent
Melting Point	: 300°C
Critical Temperature	: 200°C
Working Stretch	: <1%
Fiber Water Absorption	: Approx. %1
Wet Abrasion	: Excellent
Dry Abrasion	: Excellent
Standard	: -
Length	: 100-200 m Plastic/Wooden Spool or Coil

Other Colours & Larger Diameters Upon Request

DIA (mm)	Weight (kg/100m)	B.Load (kgf)	DIA (inch)	Weight (lbs/100ft)	B.Load (lbs)
3	0,60	720	1/8"	0,40	1.584
4	1,20	1.430	5/32"	0,81	3.146
5	2,10	2.500	3/16"	1,41	5.500
6	3,00	3.575	1/4"	2,02	7.865
8	5,40	6.450	5/16"	3,63	14.190
10	8,10	9.700	3/8"	5,44	21.340
12	12,90	15.000	1/2"	8,67	33.000
14	15,60	17.700	9/16"	10,48	38.940
16	19,50	21.825	5/8"	13,10	48.015
18	23,40	25.700	3/4"	15,72	56.540
20	31,20	33.800	13/16"	20,97	74.360
22	39,00	41.750	7/8"	26,21	91.850
24	42,90	45.350	1"	28,83	99.770

*Unspliced Break Load (All Tests are in Accordance with ISO 2307)



Vectran™



DYNE K®

APPLICATIONS

- Spi Pole Uphaul
- Spi Pole Foreguy
- Backstays
- Vang
- Cunningham
- Main Outhaul

See Page 25

BENEFITS / FEATURES

- Superior Abrasion Resistance
- Excellent Breaking Load (SK99)
- Buoyant
- Durable
- Very Low Stretch
- Lightweight
- Easy to Splice
- Does not Kink

SPECIFICATIONS

Material	: Coated: Dyneema® SK 78/99 Fiber
Specific Gravity	: 0,97 kg/dm ³
Construction	: 12 Strand Braided
UV Resistance	: Excellent
Chemical Resistance	: Excellent
Melting Point	: 147°C
Critical Temperature	: 65°C
Working Stretch	: <1%
Fiber Water Absorption	: None
Wet Abrasion	: Excellent
Dry Abrasion	: Excellent
Standard	: EN ISO 10325
Length	: 100-200 m Plastic/Wooden Spool or Coil

Other Colours & Larger Diameters Upon Request

DIA (mm)	Weight (kg/100m)	B.Load (kgf) SK78	B.Load (kgf) SK99	DIA (inch)	Weight (lbs/100ft)	B.Load (lbs) SK78	B.Load (lbs) SK99
2	0,26	450	530	3/32"	0,17	990	1.166
3	0,52	950	1.120	1/8"	0,34	2.090	2.464
4	1,38	1.700	2.010	5/32"	0,64	3.740	4.422
5	1,58	2.700	3.190	3/16"	1,01	5.940	7.018
6	2,30	4.080	4.810	1/4"	1,55	8.976	10.582
8	4,00	7.040	8.310	5/16"	2,69	15.488	18.282
10	6,10	10.750	12.690	3/8"	4,10	23.650	27.918
12	8,70	15.300	18.050	1/2"	5,85	33.660	39.710
14	11,70	20.400	24.070	9/16"	7,86	44.880	52.954
16	15,20	26.010	30.690	5/8"	10,21	57.222	67.518
18	19,00	32.130	37.910	3/4"	12,77	70.686	83.402
20	23,30	38.760	45.740	13/16"	15,66	85.272	100.628
22	28,00	45.900	54.160	7/8"	18,82	100.980	119.152
24	33,10	53.040	62.590	1"	22,24	116.688	137.698
26	38,60	61.200	72.220	1-1/16"	25,94	134.640	158.884
28	44,50	69.870	82.450	1-1/8"	29,90	153.714	181.390
30	50,80	79.050	93.280	1-1/4"	34,14	173.910	205.216
32	57,50	88.230	104.110	1-5/16"	38,64	194.106	229.042
34	64,60	98.430	116.150	1 3/8"	43,41	216.546	255.530
36	72,20	109.140	128.790	1-1/2"	48,52	240.108	283.338
38	80,10	119.850	141.420	1-9/16"	53,83	263.670	311.124
40	88,40	131.070	154.660	1-5/8"	59,40	288.354	340.252

*Unspliced Break Load (All Tests are in Accordance with ISO 2307)

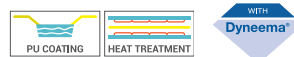

DYNE K[®] EXTREME

APPLICATIONS

Spi Pole Uphaul
Spi Pole Foreguy
Backstays
Vang
Cunningham
Main Outhaul

See Page 25

BENEFITS / FEATURES

Superior Abrasion Resistance
Superior Breaking Load (SK99)
Buoyant
Durable
Extremely Low Stretch
Lightweight
Easy to Splice
Does not Kink

SPECIFICATIONS

Material	: Coated: Dyneema [®] SK 78/99 Fiber
Specific Gravity	: 0,97 kg/dm ³
Construction	: 12 Strand Braided
UV Resistance	: Excellent
Chemical Resistance	: Excellent
Melting Point	: 147°C
Critical Temperature	: 65°C
Working Stretch	: <1%
Fiber Water Absorption	: None
Wet Abrasion	: Excellent
Dry Abrasion	: Excellent
Standard	: EN ISO 10325
Length	: 100-200 m Plastic/Wooden Spool or Coil

Other Colours & Larger Diameters Upon Request

DIA (mm)	Weight (kg/100m)	B.Load (kgf) SK78	B.Load (kgf) SK99	DIA (inch)	Weight (lbs/100ft)	B.Load (lbs) SK78	B.Load (lbs) SK99
2	0,25	490	580	3/32"	0,17	1.078	1.276
3	0,50	1.030	1.220	1/8"	0,34	2.266	2.684
4	1,00	1.830	2.160	5/32"	0,67	4.026	4.752
5	1,50	2.910	3.430	3/16"	1,01	6.402	7.546
6	2,00	4.390	5.180	1/4"	1,34	9.658	11.396
8	3,75	7.570	8.930	5/16"	2,52	16.654	19.646
10	6,00	11.560	13.640	3/8"	4,03	25.432	30.008
12	8,50	16.450	19.410	1/2"	5,71	36.190	42.702
14	11,40	21.930	25.880	9/16"	7,66	48.246	56.936
16	14,80	27.960	32.990	5/8"	9,95	61.512	72.578
18	18,50	34.540	40.760	3/4"	12,43	75.988	89.672
20	22,70	41.670	49.170	13/16"	15,25	91.674	108.174
22	27,20	49.350	58.230	7/8"	18,28	108.570	128.106
24	32,20	57.020	67.280	1"	21,64	125.444	148.016
26	37,50	65.790	77.630	1-1/16"	25,20	144.738	170.786
28	43,30	75.120	88.640	1-1/8"	29,10	165.264	195.008
30	49,40	84.980	100.280	1-1/4"	33,20	186.956	220.616
32	55,90	94.850	111.920	1-5/16"	37,56	208.670	246.224
34	62,80	105.820	124.870	1 3/8"	42,20	232.804	274.714
36	70,10	117.330	138.450	1-1/2"	47,11	258.126	304.590
38	77,80	128.840	152.030	1-9/16"	52,28	283.448	334.466
40	85,90	140.910	166.270	1-5/8"	57,72	310.002	365.794

*Unspliced Break Load (All Tests are in Accordance with ISO 2307)



DYNE K[®] EXTREME ▲ RACING LINES



STORM D PRO®

STORM D PRO® is a lightweight rope that provides safe and reliable performance as well as superior strength and remarkable low-stretch capabilities. Besides having superior strength, our STORM D PRO® series also maintain a smooth surface with excellent grips on winches and its resistance to abrasion makes it ideal for clutches and jammers, which gives greater endurance and longevity.

APPLICATIONS

Main Halyard
Genoa Halyard
Spi Halyard
Reefing Lines
Main Sheet
Genoa Sheet
Spi Sheet
Spi Guys

[See Page 25](#)

BENEFITS / FEATURES

Good Performance in Jammers
Excellent Breaking Load (SK99)
Low Stretch
Easy to Splice

SPECIFICATIONS

Material	:	Cover: HT Polyester Fiber Core: Coated Dyneema® SK78/99 Fiber
Specific Gravity	:	0,99-1,20 kg/dm ³
Construction	:	Cover: 24-32 Plaited Core: 12 Plaited
UV Resistance	:	Excellent
Chemical Resistance	:	Good
Melting Point	:	147-256°C
Critical Temperature	:	65°C
Working Stretch	:	<1,5%
Fiber Water Absorption	:	Approx. %0-1
Wet Abrasion	:	Good
Dry Abrasion	:	Good
Standard	:	-
Length	:	100-200 m Plastic/Wooden Spool or Coil

[Other Colours & Larger Diameters Upon Request](#)

STORM D PRO® RACING LINES

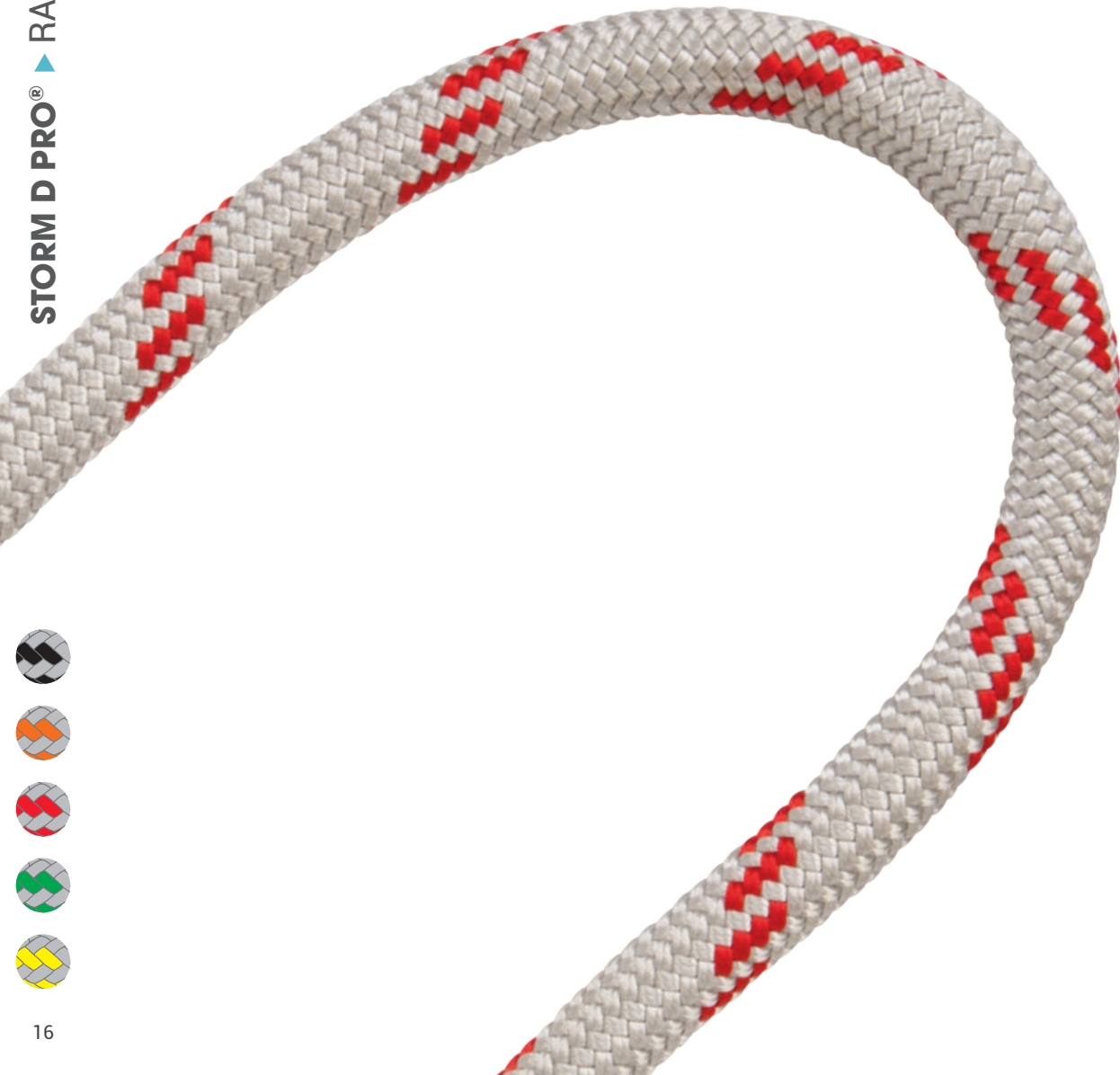

DIA (mm)	Weight (kg/100m)	B.Load (kgf) SK78	B.Load (kgf) SK99	DIA (inch)	Weight (lbs/100ft)	B.Load (lbs) SK78	B.Load (lbs) SK99
8	4,65	3.600	4.300	5/16"	3,12	7.920	9.460
10	6,40	5.650	6.700	3/8"	4,30	12.430	14.740
12	9,10	8.000	9.600	1/2"	6,12	17.600	21.120
14	12,80	10.400	12.500	9/16"	8,60	22.880	27.500
16	16,60	14.000	16.750	5/8"	11,16	30.800	36.850
18	20,85	18.000	21.500	3/4"	14,01	39.600	47.300
20	26,10	22.000	26.400	13/16"	17,54	48.400	58.080
22	28,45	25.000	30.000	7/8"	19,12	55.000	66.000
24	33,45	29.000	34.750	1"	22,48	63.800	76.450

*Unspliced Break Load (All Tests are in Accordance with ISO 2307)



STORM D PRO® MIX ▲ RACING LINES



STORM D PRO® MIX DT

APPLICATIONS

Main Sheet
Genoa Sheet
Spi Sheet
Spi Guys
Gennaker Tack-Line
Backstays

See Page 25

BENEFITS / FEATURES

Excellent Grip on Winches
Excellent Breaking Load (SK99)
Good Heat Resistance
Low Stretch
Easy to Splice



SPECIFICATIONS

Material	:	Cover: %50 Technora® Fiber %50 Dyneema® SK 78 Fiber Core: Coated Dyneema® SK 78/99 Fiber
Specific Gravity	:	0,99-1,20 kg/dm³
Construction	:	Cover: 24-32 Plaited Core: 12 Plaited
UV Resistance	:	Good
Chemical Resistance	:	Excellent
Melting Point	:	147°C
Critical Temperature	:	65°C
Working Stretch	:	<1,5%
Fiber Water Absorption	:	Approx. %0-1
Wet Abrasion	:	Excellent
Dry Abrasion	:	Excellent
Standard	:	-
Length	:	100-200 m Plastic/Wooden Spool or Coil

Other Colours & Larger Diameters Upon Request

DIA (mm)	Weight (kg/100m)	B.Load (kgf) DT78	B.Load (kgf) DT99	DIA (inch)	Weight (lbs/100ft)	B.Load (lbs) DT78	B.Load (lbs) DT99
8	4,05	3.600	4.300	5/16"	2,72	7.920	9.460
10	6,20	5.650	6.700	3/8"	4,17	12.430	14.740
12	8,55	8.000	9.600	1/2"	5,75	17.600	21.120
14	12,20	10.400	12.500	9/16"	8,20	22.880	27.500
16	15,55	14.000	16.750	5/8"	10,45	30.800	36.850
18	20,90	18.000	21.500	3/4"	14,04	39.600	47.300
20	24,80	22.000	26.400	13/16"	16,67	48.400	58.080
22	27,70	25.000	30.000	7/8"	18,61	55.000	66.000
24	32,85	29.000	34.750	1"	22,08	63.800	76.450

*Unspliced Break Load (All Tests are in Accordance with ISO 2307)



STORM D PRO® MIX TP

APPLICATIONS

Main Halyard
Genoa Halyard
Spi Halyard
Reefing Lines
Main Sheet
Genoa Sheet

See Page 25

BENEFITS / FEATURES

Good Grip on Winches
Excellent Performance in Jammers
Excellent Breaking Load (SK99)
Very Good Heat Resistance
Low Stretch
Easy to Splice



SPECIFICATIONS

Material	: Cover: %50 Technora® Fiber %50 HT Polyester Fiber Core: Coated Dyneema® SK 78/99 Fiber
Specific Gravity	: 0,99-1,20 kg/dm³
Construction	: Cover: 24-32 Plaited Core: 12 Plaited
UV Resistance	: Sufficient
Chemical Resistance	: Excellent
Melting Point	: 147-256°C
Critical Temperature	: 65°C
Working Stretch	: <1,5%
Fiber Water Absorption	: Approx. %1-2
Wet Abrasion	: Excellent
Dry Abrasion	: Excellent
Standard	: -
Length	: 100-200 m Plastic/Wooden Spool or Coil

Other Colours & Larger Diameters Upon Request

DIA (mm)	Weight (kg/100m)	B.Load (kgf) TP78	B.Load (kgf) TP99	DIA (inch)	Weight (lbs/100ft)	B.Load (lbs) TP78	B.Load (lbs) TP99
8	4,35	3.600	4.300	5/16"	2,92	7.920	9.460
10	6,50	5.650	6.700	3/8"	4,37	12.430	14.740
12	9,15	8.000	9.600	1/2"	6,15	17.600	21.120
14	13,00	10.400	12.500	9/16"	8,74	22.880	27.500
16	17,30	14.000	16.750	5/8"	11,63	30.800	36.850
18	21,60	18.000	21.500	3/4"	14,52	39.600	47.300
20	26,90	22.000	26.400	13/16"	18,08	48.400	58.080
22	29,30	25.000	30.000	7/8"	19,69	55.000	66.000
24	33,90	29.000	34.750	1"	22,78	63.800	76.450

*Unspliced Break Load (All Tests are in Accordance with ISO 2307)



STORM D PRO® MIX TP ▲ RACING LINES

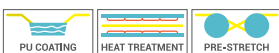

Technora





DYNE K® SHACKLE

APPLICATIONS

Winch Shackle

BENEFITS / FEATURES

- Buoyant
- Ultra Light
- Very Low Stretch
- Shackles are Made of Dyneema®
- Easy to Use
- Extremely Durable



SPECIFICATIONS

Material	:	Coated Dyneema® SK 78 Fiber
Specific Gravity	:	0,97 kg/dm ³
Construction	:	12 Strand Plaited
UV Resistance	:	Excellent
Chemical Resistance	:	Excellent
Melting Point	:	147°C
Critical Temperature	:	65°C
Working Stretch	:	<1%
Wet Abrasion	:	Excellent
Dry Abrasion	:	Excellent
Standard	:	ISO 10325
Length	:	-

Other Colours & Larger Diameters Upon Request

DIA (mm)	B.Load (kgf)	SWL (kgf)	Length (cm)	DIA (inch)	B.Load (lbs)	SWL (lbs)	Length (Ft)
4	855	478	8,50	5/32"	1.881	1.052	0,28
6	1.150	575	9,50	1/4"	2.530	1.265	0,31
7	1.485	743	11,00	9/32"	3.267	1.635	0,36
8	2.340	1.170	11,00	5/16"	5.148	2.574	0,36
10	3.360	1.688	11,50	3/8"	7.392	3.714	0,38
12	4.670	2.375	12,50	1/2"	10.274	5.225	0,41
14	5.980	2.990	15,00	9/16"	13.156	6.578	0,49
18	9.380	4.690	17,50	3/4"	20.636	10.318	0,57

*Unspliced Break Load (All Tests are in Accordance with ISO 2307)



ROCK SOFT-D

APPLICATIONS

Genoa Sheet
Spi Sheet
Gennaker Tack-Line

See Page 25

BENEFITS / FEATURES

Very Suitable for Jammers
Comfortable Handling
Low Stretch
Lightweight
Excellent Dinghy Sheet
High Knotted Strength



SPECIFICATIONS

Material	: Blended Dyneema® SK 78-Polyester Staple Fiber
Specific Gravity	: 0,99-1,20 kg/dm ³
Construction	: 8 Plaited (Hollow Braid)
UV Resistance	: Excellent
Chemical Resistance	: Good
Melting Point	: 147°C
Critical Temperature	: 65°C
Working Stretch	: <2%
Fiber Water Absorption	: Approx. %0-1
Wet Abrasion	: Good
Dry Abrasion	: Good
Standard	: -
Length	: 100-200 m Plastic Spool or Coil

Other Colours & Larger Diameters Upon Request

DIA (mm)	Weight (kg/100m)	B.Load (kgf)	DIA (inch)	Weight (lbs/100ft)	B.Load (lbs)
4	1,20	500	5/32"	0,81	1.100
5	1,55	750	3/16"	1,04	1.650
6	1,95	1.000	1/4"	1,31	2.200
7	2,75	1.250	9/32"	1,85	2.750
8	3,85	1.500	5/16"	2,59	3.300
10	5,80	2.600	3/8"	3,90	5.720

*Unspliced Break Load (All Tests are in Accordance with ISO 2307)

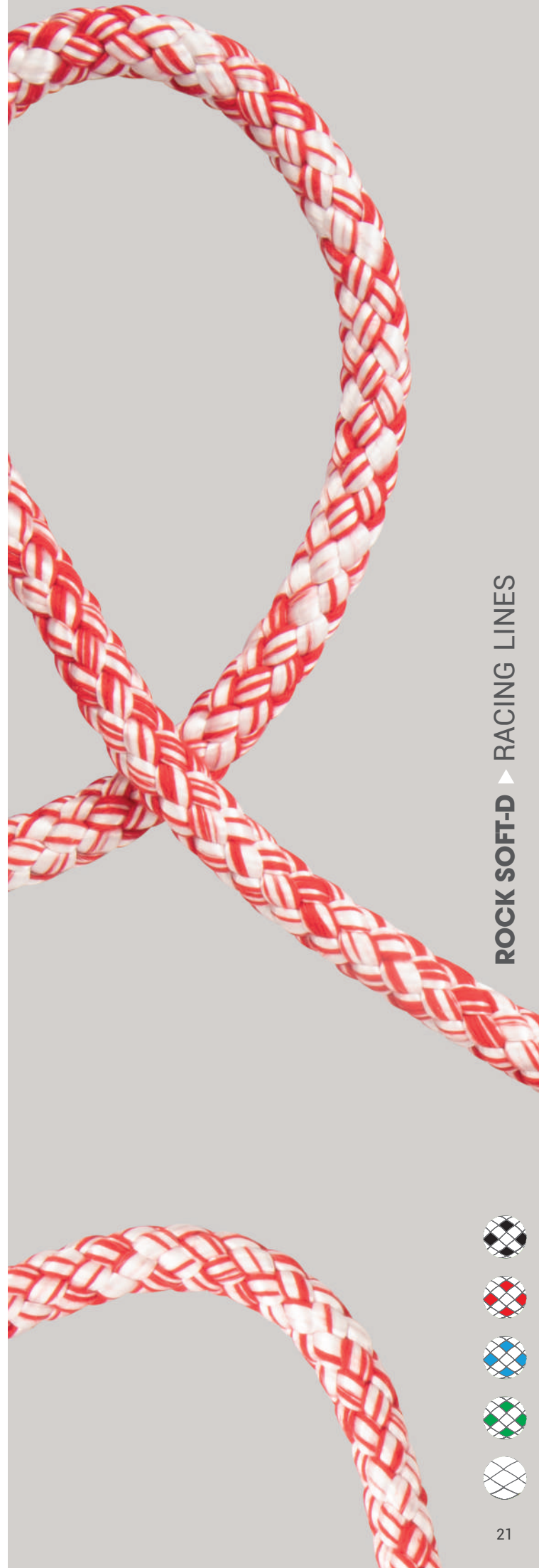

ROCK SOFT-D ▲ RACING LINES





DYNE COVER LIGHT

APPLICATIONS

Special Cover

BENEFITS / FEATURES

Ideal for Protection Against Abrasion
Excellent Performance in Jammers
Easy Handling
Buoyant

SPECIFICATIONS

Material	: 100% Dyneema® SK 78 Fiber
Specific Gravity	: 0,97 kg/dm ³
Construction	: 24-32-40-48 Plaited
UV Resistance	: Excellent
Chemical Resistance	: Excellent
Melting Point	: 147°C
Critical Temperature	: 65°C
Working Stretch	: <3%
Wet Abrasion	: Excellent
Dry Abrasion	: Excellent
Standard	: -
Length	: 100-200 m Plastic Spool

Other Colours & Larger Diameters Upon Request



VECT COVER LIGHT

APPLICATIONS

Special Cover

BENEFITS / FEATURES

Ideal for Protection Against Abrasion
Excellent Grip on Winches
Easy Handling
Good Heat Resistance

SPECIFICATIONS

Material	: 100% Vectran® Fiber
Specific Gravity	: 1,40 kg/dm ³
Construction	: 24-32-40-48 Plaited
UV Resistance	: Poor
Chemical Resistance	: Excellent
Melting Point	: 500°C
Critical Temperature	: 350°C
Working Stretch	: <3%
Wet Abrasion	: Excellent
Dry Abrasion	: Excellent
Standard	: -
Length	: 100-200 m Plastic Spool

Other Colours & Larger Diameters Upon Request

DIA (mm)	Weight (kg/100m)	B.Load (kgf)	DIA (inch)	Weight (lbs/100ft)	B.Load (lbs)
4-6			5/32"- 1/4"		
6-8			1/4"- 5/16"		
8-12			5/16"- 1/2"		
10-16			3/8"- 5/8"		
12-20			1/2"- 13/16"		

* Unspliced Break Load (All Tests are in Accordance with ISO 2307)

TECH COVER LIGHT

APPLICATIONS

Special Cover

BENEFITS / FEATURES

Ideal for Protection Against Abrasion
 Very Good Performance in Jammers
 Easy Handling
 Excellent Heat Resistance

SPECIFICATIONS

Material	: 100% Technora® Fiber
Specific Gravity	: 1,44 kg/dm ³
Construction	: 24-32-40-48 Plaited
UV Resistance	: Sufficient
Chemical Resistance	: Excellent
Melting Point	: 500°C
Critical Temperature	: 350°C
Working Stretch	: <3%
Wet Abrasion	: Excellent
Dry Abrasion	: Excellent
Standard	: -
Length	: 100-200 m Plastic Spool

Larger Diameters Upon Request

Technora

TP COVER LIGHT

APPLICATIONS

Special Cover

BENEFITS / FEATURES

Ideal for Protection Against Abrasion
 Very Good Performance in Jammers
 Easy Handling
 Very Good Heat Resistance

SPECIFICATIONS

Material	: 50% Technora® Fiber 50% HT Polyester Fiber
Specific Gravity	: Approx. 1,40 kg/dm ³
Construction	: 24-32-40-48 Plaited
UV Resistance	: Sufficient
Chemical Resistance	: Excellent
Melting Point	: 256°C
Critical Temperature	: 170°C
Working Stretch	: <3%
Wet Abrasion	: Very Good
Dry Abrasion	: Very Good
Standard	: -
Length	: 100-200 m Plastic Spool

Other Colours & Larger Diameters Upon Request

DIA (mm)	Weight (kg/100m)	B.Load (kgf)	DIA (inch)	Weight (lbs/100ft)	B.Load (lbs)
4-6			5/32"- 1/4"		
6-8			1/4"- 5/16"		
8-12			5/16"- 1/2"		
10-16			3/8"- 5/8"		
12-20			1/2"- 13/16"		

*Unspliced Break Load (All Tests are in Accordance with ISO 2307)

Technora

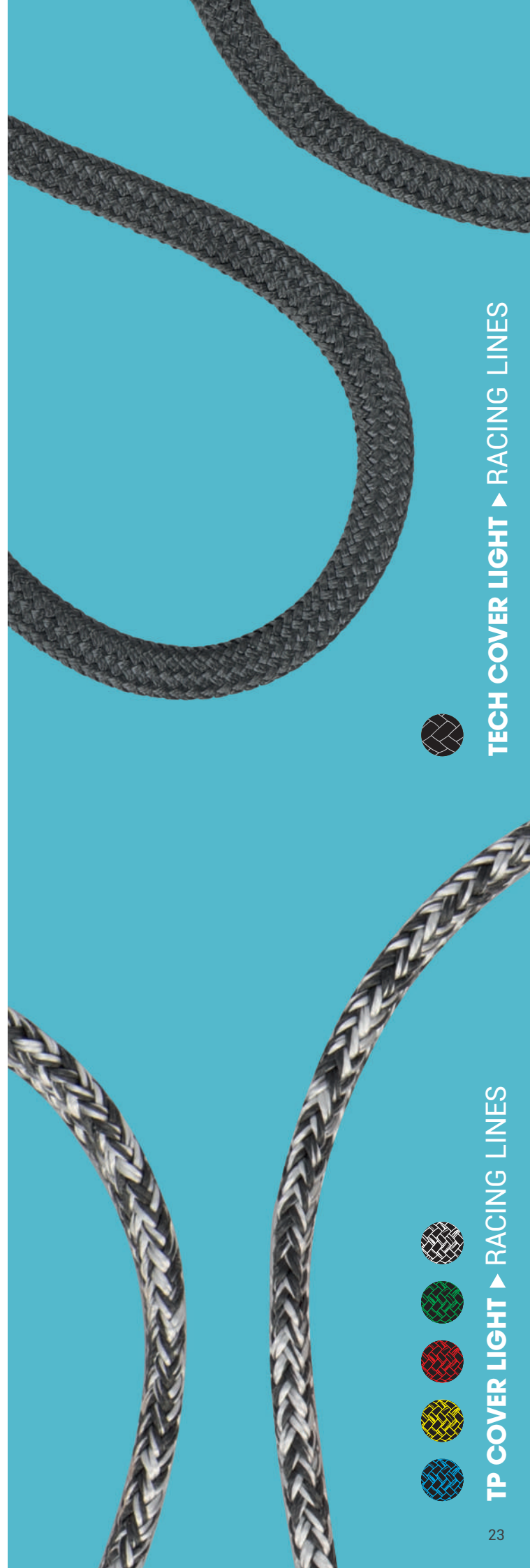

TECH COVER LIGHT ▶ RACING LINES



TP COVER LIGHT ▶ RACING LINES

SAILBOAT RIGGING DIAGRAM



ROPE APPLICATIONS FOR RACING LINES

ROPE NAMES	HALYARDS				SHEETS				CONTROL LINES											
	PAGE	MAIN	GENOA	SPI HALYARD	REEFING LINES	MAIN	GENOA	SPI SHEET	SPI GUYS	SPI POLE UPHAUL	SPI POLE FOREGUY	GENNAKER TACK-LINE	ROLLER REEFING LINE	BACKSTAYS	VANG	CUNNINGHAM	MAIN OUTHAUL	GENOA CAR TRAVELLER	MAIN CAR TRAVELLER	
REFER TO DIAGRAM	24	A	B	C	D	E	F	G	H	I	J	K	L	M	N	O	P	Q	R	
GP ROCK D® MIX TP	7	✓	✓	✓		✓	✓	✓	✓			✓								
GP ROCK D® MIX VP	8					✓	✓	✓	✓			✓								
GP ROCK D® MIX AP	9					✓	✓	✓	✓			✓								
GP ROCK D® MIX	10	✓	✓	✓		✓	✓	✓	✓	✓	✓	✓	✓		✓	✓	✓	✓	✓	
GP ROCK D® MIX DP	11	✓	✓	✓			✓			✓	✓	✓	✓		✓	✓	✓	✓	✓	
GP ROCK V®	12	✓	✓			✓			✓							✓	✓			
VECT K®	13									✓	✓				✓	✓	✓			
DYNE K®	14									✓	✓			✓	✓	✓	✓			
DYNE K® EXTREME	15									✓	✓			✓	✓	✓	✓			
STORM D PRO® / MIX	16	✓	✓	✓	✓	✓	✓	✓	✓	✓	✓	✓	✓	✓	✓	✓	✓	✓	✓	
STORM D PRO® MIX DT	18	✓	✓	✓	✓		✓			✓	✓	✓	✓	✓	✓	✓	✓	✓	✓	
STORM D PRO® MIX TP	19	✓	✓	✓	✓	✓	✓	✓	✓			✓		✓						
ROCK SOFT-D	21						✓	✓				✓								

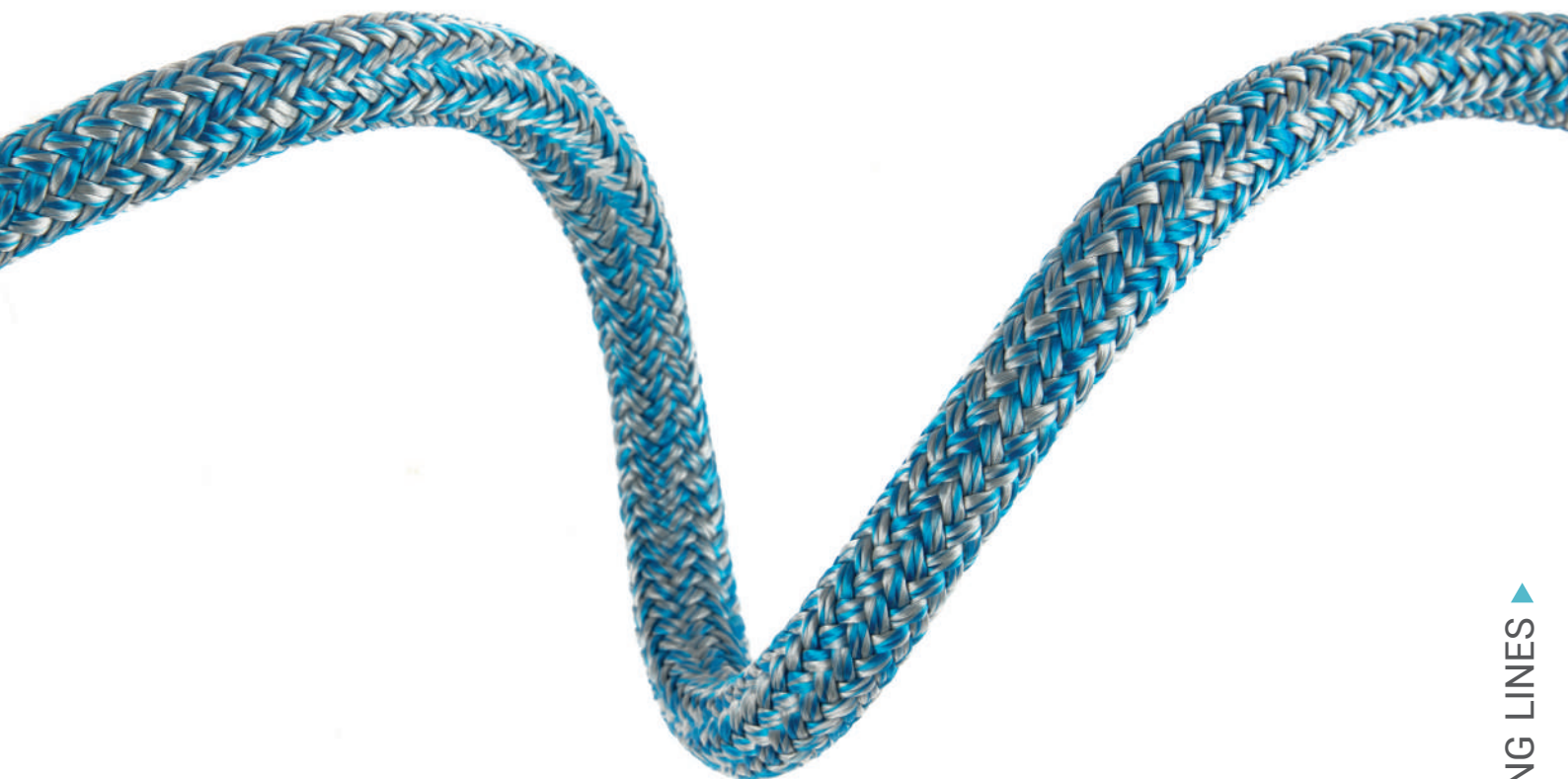

CRUISING LINES

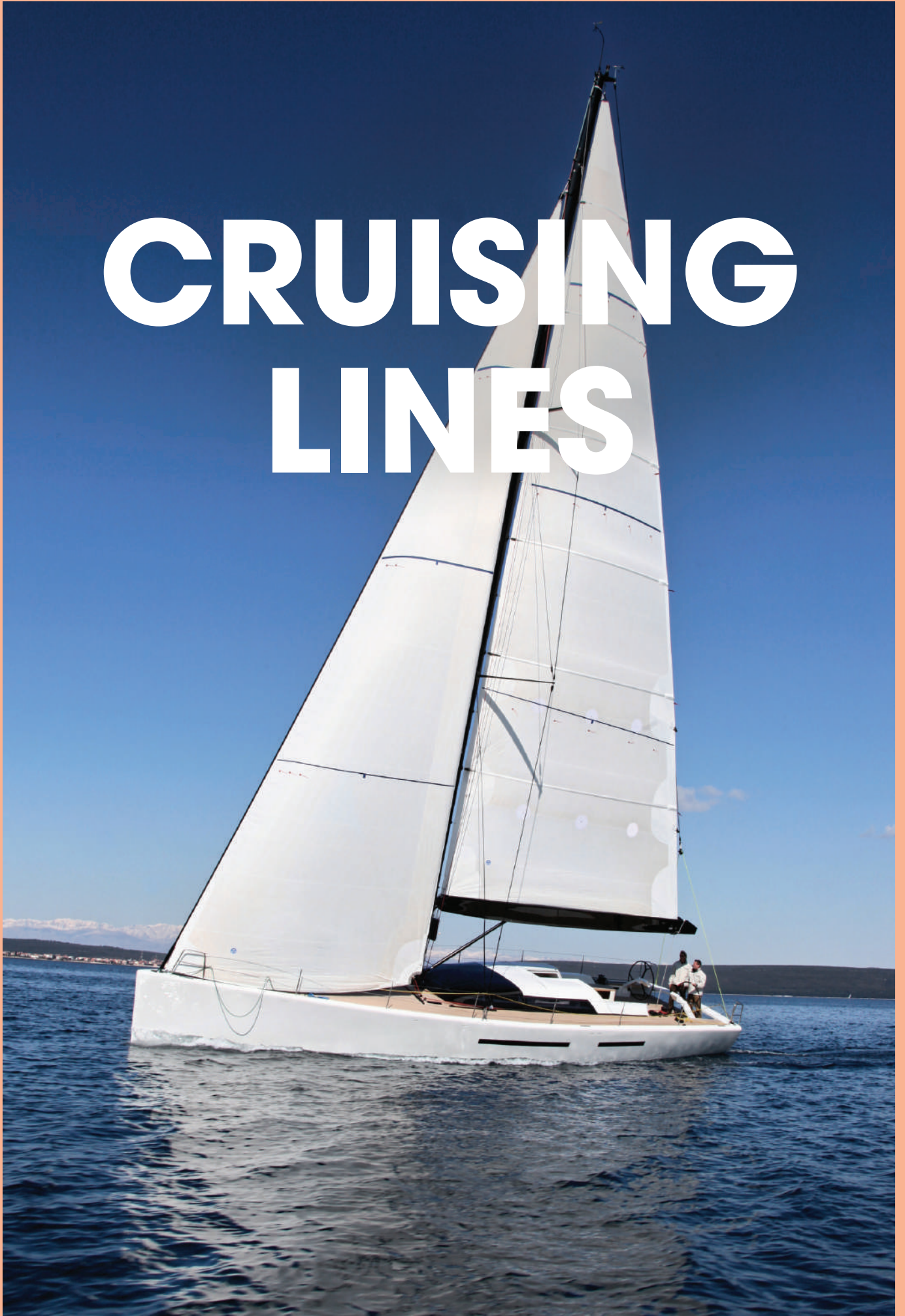

LUPES® ULTRA LITE

APPLICATIONS

Main Sheet
Genoa Sheet
Spi Sheet
Spi Guys
Spi Pole Uphaul
Genova Car Traveller
Main Car Traveller

BENEFITS / FEATURES

Easy to Splice
Cost-Efficient
Durable
Very Long Service Life
Outstanding Flexibility

See Page 37



SPECIFICATIONS

Material	:	Cover: HT Polyester Fiber Core: HT Polyester Fiber
Specific Gravity	:	1,38 kg/dm ³
Construction	:	Cover: 16 Plaited Core: 16 Plaited
UV Resistance	:	Excellent
Chemical Resistance	:	Good
Melting Point	:	256°C
Critical Temperature	:	170°C
Working Stretch	:	<6%
Fiber Water Absorption	:	Approx. %1-2
Wet Abrasion	:	Good
Dry Abrasion	:	Good
Standard	:	-
Length	:	100-200 m Plastic/Wooden Spool or Coil

Other Colours & Larger Diameters Upon Request

DIA (mm)	Weight (kg/100m)	B.Load (kgf)	DIA (inch)	Weight (lbs/100ft)	B.Load (lbs)
6	2,35	900	1/4"	1,58	1.980
8	4,50	1.635	5/16"	3,03	3.600
10	6,80	2.120	3/8"	4,57	4.664
12	8,70	3.450	1/2"	5,85	7.590
14	11,70	4.540	9/16"	7,87	9.990

* Unspliced Break Load (All Tests are in Accordance with ISO 2307)



LUPES® ULTRA LITE ▲ CRUISING LINES





LUPES® ULTRA

APPLICATIONS

- Main Halyard
- Genoa Halyard
- Spi Halyard
- Reefing Lines
- Main Sheet
- Genoa Sheet
- Spi Sheet

See Page 37

BENEFITS / FEATURES

- Easy to Splice
- Durable
- Very Long Service Life
- High Breaking Load
- Shares the Load Equally Between Cover and Core
- Stretches Less Than the Standard Polyester
- Outstanding Flexibility



SPECIFICATIONS

- Material : Cover: HT Polyester Fiber
Core: HT Polyester Fiber
- Specific Gravity : 1,38 kg/dm³
- Construction : Cover: 16-24 Plaited
Core: 16 Plaited
- UV Resistance : Excellent
- Chemical Resistance : Good
- Melting Point : 256°C
- Critical Temperature : 170°C
- Working Stretch : <4%
- Fiber Water Absorption : Approx. %1-2
- Wet Abrasion : Good
- Dry Abrasion : Good
- Standard : -
- Length : 100-200 m Plastic/Wooden Spool or Coil

Other Colours & Larger Diameters Upon Request

DIA (mm)	Weight (kg/100m)	B.Load (kgf)	DIA (inch)	Weight (lbs/100ft)	B.Load (lbs)
5	2,00	670	3/16"	1,34	1.474
6	2,85	1.090	1/4"	1,92	2.400
8	4,85	1.775	5/16"	3,26	3.910
10	6,55	2.345	3/8"	4,40	5.160
11	9,20	3.185	7/16"	6,18	7.010
12	12,00	4.615	1/2"	8,07	10.150
14	14,10	5.340	9/16"	9,48	11.750
16	18,40	7.700	5/8"	12,37	16.940
18	24,75	10.700	3/4"	16,64	23.540

*Unspliced Break Load (All Tests are in Accordance with ISO 2307)



LUPES® ULTRA FANCY

APPLICATIONS

Main Halyard
Genoa Halyard
Spi Halyard
Reefing Lines
Main Sheet
Genoa Sheet
Spi Sheet

See Page 37

BENEFITS / FEATURES

Easy to Splice
Durable
Very Long Service Life
High Breaking Load
Shares the Load Equally
Between Cover and Core
Stretches Less Than the
Standard Polyester
Outstanding Flexibility



SPECIFICATIONS

Material	:	Cover: HT Polyester Fiber Core: HT Polyester Fiber
Specific Gravity	:	1,38 kg/dm ³
Construction	:	Cover: 16-24 Plaited Core: 16 Plaited
UV Resistance	:	Excellent
Chemical Resistance	:	Good
Melting Point	:	256°C
Critical Temperature	:	170°C
Working Stretch	:	<4%
Fiber Water Absorption	:	Approx. %1-2
Wet Abrasion	:	Good
Dry Abrasion	:	Good
Standard	:	-
Length	:	100-200 m Plastic/Wooden Spool or Coil

Other Colours & Larger Diameters Upon Request

DIA (mm)	Weight (kg/100m)	B.Load (kgf)	DIA (inch)	Weight (lbs/100ft)	B.Load (lbs)
5	2,00	670	3/16"	1,34	1.474
6	2,85	1.090	1/4"	1,92	2.400
8	4,85	1.775	5/16"	3,26	3.910
10	6,55	2.345	3/8"	4,40	5.160
11	9,20	3.185	7/16"	6,18	7.010
12	12,00	4.615	1/2"	8,07	10.150
14	14,10	5.340	9/16"	9,48	11.750
16	18,40	7.700	5/8"	12,37	16.940
18	24,75	10.700	3/4"	16,64	23.540

*Unspliced Break Load (All Tests are in Accordance with ISO 2307)

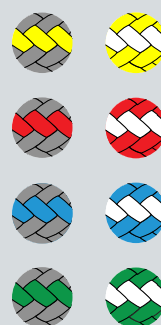

LUPES® ULTRA FANCY ▲ CRUISING LINES

LUPES® ULTRA TIGHT

APPLICATIONS

Main Halyard
 Genoa Halyard
 Spi Halyard
 Reefing Lines
 Main Sheet
 Genoa Sheet
 Spi Sheet

See Page 37

BENEFITS / FEATURES

Easy to Splice
 Durable
 Very Long Service Life
 High Breaking Load
 Shares the Load Equally
 Between Cover and Core
 Stretches Less Than the
 Standards Polyester
 Outstanding Flexibility



SPECIFICATIONS

Material	:	Cover: HT Polyester Fiber Core: HT Polyester Fiber
Specific Gravity	:	1,38 kg/dm ³
Construction	:	Cover: 32 Plaited Core: 16 Plaited
UV Resistance	:	Excellent
Chemical Resistance	:	Good
Melting Point	:	256°C
Critical Temperature	:	170°C
Working Stretch	:	<4%
Fiber Water Absorption	:	Approx. %1-2
Wet Abrasion	:	Good
Dry Abrasion	:	Good
Standard	:	-
Length	:	100-200 m Plastic/Wooden Spool or Coil

Other Colours & Larger Diameters Upon Request

DIA (mm)	Weight (kg/100m)	B.Load (kgf)	DIA (inch)	Weight (lbs/100ft)	B.Load (lbs)
6	3,15	1.090	1/4"	2,12	2.400
8	5,00	1.775	5/16"	3,36	3.910
10	7,00	2.345	3/8"	4,71	5.160
11	9,10	3.185	7/16"	6,12	7.010
12	12,50	4.615	1/2"	8,40	10.150
14	14,50	5.340	9/16"	9,75	11.750
16	18,60	7.700	5/8"	12,50	16.940
18	25,75	10.700	3/4"	17,31	23.540

*Unspliced Break Load (All Tests are in Accordance with ISO 2307)

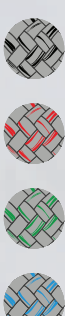

LUPES® SOFT

APPLICATIONS

Main Sheet
Genoa Sheet
Spi Sheet

See Page 37

BENEFITS / FEATURES

Easy to Splice
Suitable for Winches
Excellent Grip
Supple Surface
Outstanding Flexibility



SPECIFICATIONS

Material	:	Cover: Polyester Staple Fiber Core: HT Polyester Fiber
Specific Gravity	:	1,38 kg/dm ³
Construction	:	Cover: 16-20-24 Plaited Core: 12 Plaited
UV Resistance	:	Good
Chemical Resistance	:	Good
Melting Point	:	256°C
Critical Temperature	:	170°C
Working Stretch	:	<6%
Fiber Water Absorption	:	Approx. %1-2
Wet Abrasion	:	Sufficient
Dry Abrasion	:	Sufficient
Standard	:	-
Length	:	100-200 m Plastic Spool

Other Colours & Larger Diameters Upon Request

DIA (mm)	Weight (kg/100m)	B.Load (kgf)	DIA (inch)	Weight (lbs/100ft)	B.Load (lbs)
6	2,70	1.080	1/4"	1,81	2.376
8	4,10	1.550	5/16"	2,76	3.410
10	6,65	2.330	3/8"	4,47	5.126
12	9,50	3.270	1/2"	6,38	7.194
14	13,60	4.370	9/16"	9,14	9.614
16	17,15	5.630	5/8"	11,52	12.386

*Unspliced Break Load (All Tests are in Accordance with ISO 2307)



LUPES® SOFT ▲ CRUISING LINES

CLASSIC LOOK



LUPES® PLAIN

APPLICATIONS

Main Sheet
 Genoa Sheet
 Spi Sheet
 Spi Guys
 Spi Pole Uphaul
 Genova Car Traveller
 Main Car Traveller

BENEFITS / FEATURES

Easy to Splice
 Cost-Efficient
 Durable
 Very Long Service Life
 Flexible

See Page 37



SPECIFICATIONS

Material	:	Cover: HT Polyester Fiber Core: HT Polyester Fiber
Specific Gravity	:	1,38 kg/dm ³
Construction	:	Cover: 24-32 Plaited Core: 12 Plaited
UV Resistance	:	Excellent
Chemical Resistance	:	Good
Melting Point	:	256°C
Critical Temperature	:	170°C
Working Stretch	:	<6%
Fiber Water Absorption	:	Approx. %1-2
Wet Abrasion	:	Good
Dry Abrasion	:	Good
Standard	:	EN ISO 10547
Length	:	100-200 m Plastic/Wooden Spool or Coil

Other Colours & Larger Diameters Upon Request

DIA (mm)	Weight (kg/100m)	B.Load (kgf)	DIA (inch)	Weight (lbs/100ft)	B.Load (lbs)
6	3,15	1.080	1/4"	2,12	2.376
8	5,30	1.550	5/16"	3,56	3.410
10	8,20	2.330	3/8"	5,51	5.126
12	11,45	3.270	1/2"	7,69	7.194
14	15,45	4.370	9/16"	10,38	9.614
16	19,65	5.630	5/8"	13,20	12.386
18	25,70	7.000	3/4"	17,27	15.400
20	31,75	8.600	13/16"	21,34	18.920
22	38,25	10.300	7/8"	25,70	22.660
24	44,80	13.100	1"	30,11	28.820

*Unspliced Break Load (All Tests are in Accordance with ISO 2307)



LUPES® PLAIN TIGHT

APPLICATIONS

Main Sheet
 Genoa Sheet
 Spi Sheet
 Spi Guys
 Spi Pole Uphaul
 Genova Car Traveller
 Main Car Traveller

See Page 37

BENEFITS / FEATURES

Cost-Efficient
 Durable
 Very Long Service Life
 Flexible



SPECIFICATIONS

Material	:	Cover: HT Polyester Fiber Core: HT Polyester Fiber
Specific Gravity	:	1,38 kg/dm ³
Construction	:	Cover: 32 Plaited Core: 12 Plaited
UV Resistance	:	Excellent
Chemical Resistance	:	Good
Melting Point	:	256°C
Critical Temperature	:	170°C
Working Stretch	:	<6%
Fiber Water Absorption	:	Approx. %1-2
Wet Abrasion	:	Good
Dry Abrasion	:	Good
Standard	:	EN ISO 10547
Length	:	100-200 m Plastic/Wooden Spool or Coil

Other Colours & Larger Diameters Upon Request

DIA (mm)	Weight (kg/100m)	B.Load (kgf)	DIA (inch)	Weight (lbs/100ft)	B.Load (lbs)
6	3,15	1.080	1/4"	2,12	2.376
8	5,30	1.550	5/16"	3,56	3.410
10	8,45	2.330	3/8"	5,68	5.126
12	11,25	3.270	1/2"	7,56	7.194
14	15,45	4.370	9/16"	10,38	9.614
16	19,65	5.630	5/8"	13,20	12.386
18	25,70	7.000	3/4"	17,27	15.400
20	31,75	8.600	13/16"	21,34	18.920
22	38,25	10.300	7/8"	25,70	22.660
24	44,80	13.100	1"	30,11	28.820

*Unspliced Break Load (All Tests are in Accordance with ISO 2307)

LUPES® PLAIN TIGHT ▲ CRUISING LINES



LUPES® LS MIX

LUPES LS MIX® is perfectly designed for you to **"UPGRADE YOUR"** halyards and sheets of your cruising boat. Our unique Pre-Stretch & heat setting technology provides extra low elongation and high strength featuring a very soft hand which is easily gripped.

APPLICATIONS

Main Halyard
Genoa Halyard
Spi Halyard
Reefing Lines
Main Sheet
Genoa Sheet
Spi Sheet

See Page 37

BENEFITS / FEATURES

Easy to Splice
Durable
Very Long Service Life
High Breaking Load
Shares the Load Equally
Between Cover and Core
Stretches Less Than the
Standard Polyester

SPECIFICATIONS

Material	: Cover: HT Polyester Fiber Core: Coated HT Polyester Fiber
Specific Gravity	: 1,38 kg/dm ³
Construction	: Cover: 24-32 Plaited Core: 12 Plaited
UV Resistance	: Excellent
Chemical Resistance	: Good
Melting Point	: 256°C
Critical Temperature	: 170°C
Working Stretch	: <4%
Fiber Water Absorption	: Approx. %1-2
Wet Abrasion	: Good
Dry Abrasion	: Good
Standard	: EN ISO 10547
Length	: 100-200 m Plastic/Wooden Spool or Coil

Other Colors & Larger Diameters Upon Request

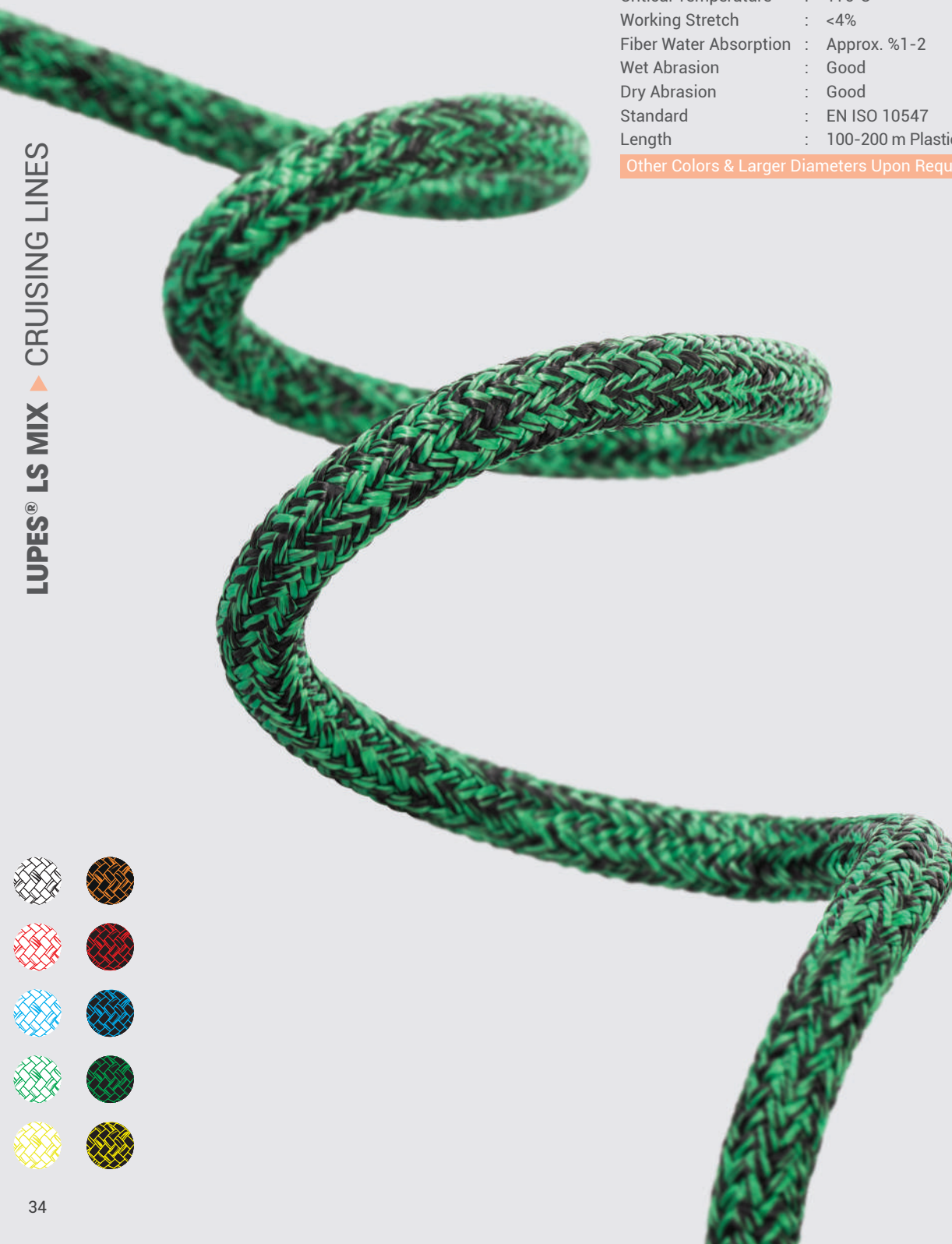

LUPES® LS MIX ▶ CRUISING LINES

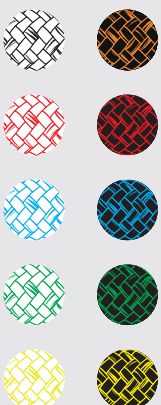

DIA (mm)	Weight (kg/100m)	B.Load (kgf)	DIA (inch)	Weight (lbs/100ft)	B.Load (lbs)
6	3,10	1.200	1/4"	2,08	2.640
8	5,25	1.700	5/16"	3,53	3.740
10	8,10	2.560	3/8"	5,44	5.632
12	11,35	3.600	1/2"	7,63	7.920
14	15,30	4.800	9/16"	10,28	10.560
16	19,45	6.500	5/8"	13,07	14.300
18	25,45	8.200	3/4"	17,10	18.040
20	31,45	10.000	13/16"	21,13	22.000
22	37,90	12.000	7/8"	25,47	26.400
24	44,40	14.250	1"	29,84	31.350

*Unspliced Break Load (All Tests are in Accordance with ISO 2307)



LUPES® LS WORLD ▲ CRUISING LINES

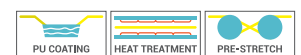



LUPES® LS TIGHT

APPLICATIONS

Main Halyard
 Genoa Halyard
 Spi Halyard
 Reefing Lines
 Main Sheet
 Genoa Sheet
 Spi Sheet

See Page 37

BENEFITS / FEATURES

Durable
 Very Long Service Life
 High Breaking Load
 Shares the Load Equally
 Between Cover and Core
 Stretches Less Than the
 Standard Polyester



SPECIFICATIONS

Material	:	Cover: HT Polyester Fiber Core: Coated HT Polyester Fiber
Specific Gravity	:	1,38 kg/dm ³
Construction	:	Cover: 32 Plaited Core: 12 Plaited
UV Resistance	:	Excellent
Chemical Resistance	:	Good
Melting Point	:	256°C
Critical Temperature	:	170°C
Working Stretch	:	<4%
Fiber Water Absorption	:	Approx. %1-2
Wet Abrasion	:	Good
Dry Abrasion	:	Good
Standard	:	EN ISO 10547
Length	:	100-200 m Plastic/Wooden Spool or Coil

Other Colours & Larger Diameters Upon Request

DIA (mm)	Weight (kg/100m)	B.Load (kgf)	DIA (inch)	Weight (lbs/100ft)	B.Load (lbs)
6	3,10	1.200	1/4"	2,08	2.640
8	5,30	1.700	5/16"	3,56	3.740
10	8,35	2.560	3/8"	5,61	5.632
12	11,10	3.600	1/2"	7,46	7.920
14	15,30	4.800	9/16"	10,28	10.560
16	19,45	6.500	5/8"	13,07	14.300
18	25,45	8.200	3/4"	17,10	18.040
20	31,45	10.000	13/16"	21,13	22.000
22	37,90	12.000	7/8"	25,47	26.400
24	44,40	14.250	1"	29,84	31.350

*Unspliced Break Load (All Tests are in Accordance with ISO 2307)



ROPE APPLICATION FOR CRUISING LINES

ROPE NAMES	HALYARDS					SHEETS				CONTROL LINES										
	PAGE	MAIN	GENOA	SPI HALYARD	REEFING LINES	MAIN	GENOA	SPI SHEET	SPI GUYS	SPI POLE UPHAUL	SPI POLE FOREGUY	GENNAKER TACK-LINE	ROLLER REEFING LINE	BACKSTAYS	VANG	CUNNINGHAM	MAIN OUTHAUL	GENOA CAR TRAVELLER	MAIN CAR TRAVELLER	CONTROL LINE
DYNE K®	14										✓		✓			✓		✓	✓	✓
DYNE K® EXTREME	15										✓		✓			✓		✓	✓	✓
STORM D PRO® / MIX	16	✓	✓	✓	✓	✓	✓	✓	✓	✓	✓	✓	✓	✓	✓	✓	✓	✓	✓	✓
LUPES® ULTRA LITE	27					✓	✓	✓	✓	✓								✓	✓	
LUPES® ULTRA	28	✓	✓	✓	✓	✓	✓	✓	✓	✓								✓		
LUPES® ULTRA FANCY	29	✓	✓	✓	✓	✓	✓	✓	✓	✓								✓		
LUPES® ULTRA TIGHT	30	✓	✓	✓	✓	✓	✓	✓	✓	✓								✓		
LUPES® SOFT	31					✓	✓	✓												
LUPES® PLAIN	32					✓	✓	✓	✓	✓								✓	✓	
LUPES® PLAIN TIGHT	33					✓	✓	✓	✓	✓								✓	✓	
LUPES® LS MIX	34	✓	✓	✓	✓	✓	✓	✓	✓	✓								✓		
LUPES® LS WORLD	35	✓	✓	✓	✓	✓	✓	✓	✓	✓								✓		
LUPES® LS TIGHT	36	✓	✓	✓	✓	✓	✓	✓	✓	✓								✓		

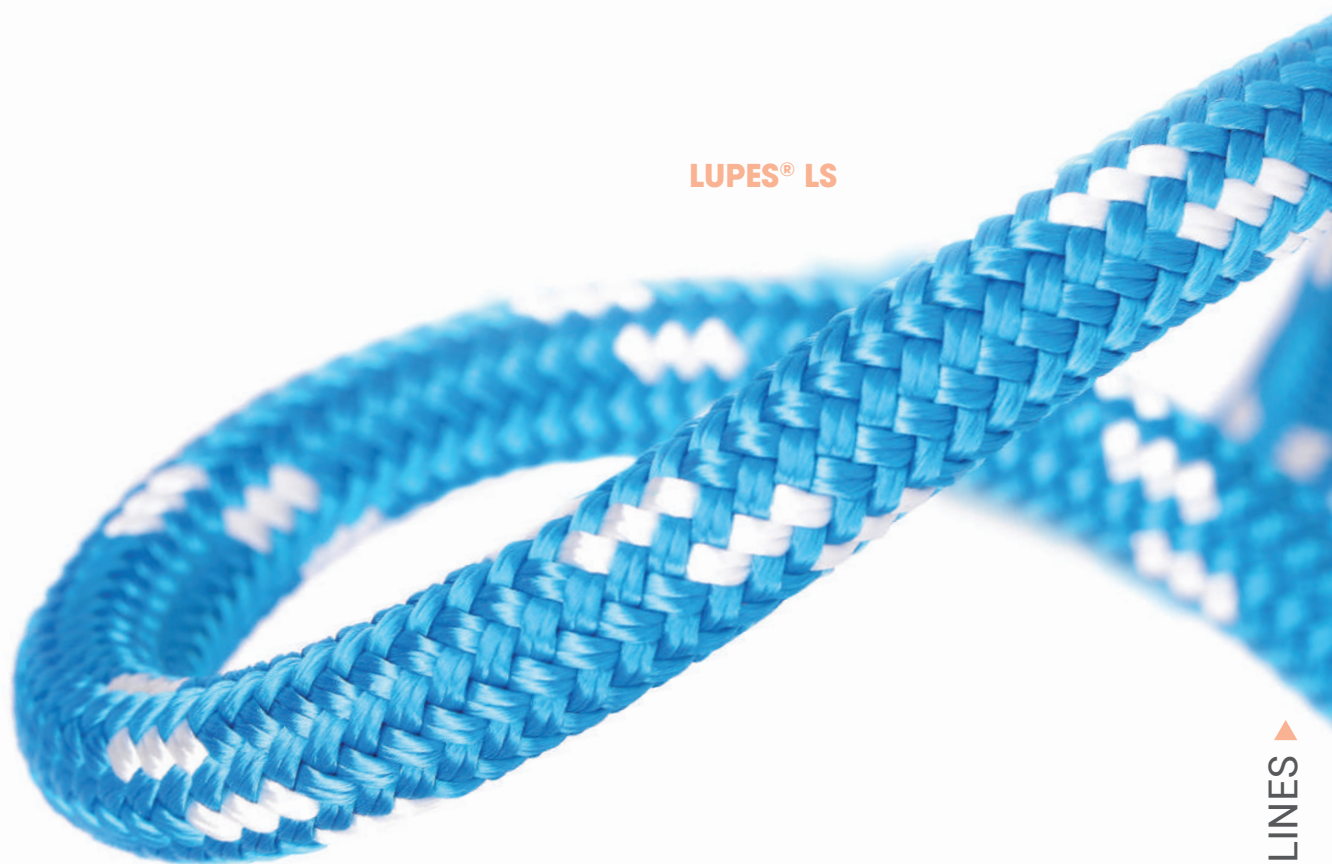

LUPES® LS

DINGHY LINES



DYNE K[®] EXTREME

APPLICATIONS

Main Halyard

See Page 47

BENEFITS / FEATURES

Superior Abrasion Resistance
 Superior Breaking Load (SK 99)
 Buoyant
 Extremely Low Stretch
 Lightweight

SPECIFICATIONS

Material	:	Coated: Dyneema [®] SK 78 / 99 Fiber
Specific Gravity	:	0,97 kg/dm ³
Construction	:	12 Strand Braided
UV Resistance	:	Excellent
Chemical Resistance	:	Excellent
Melting Point	:	147°C
Critical Temperature	:	65°C
Working Stretch	:	<1%
Fiber Water Absorption	:	None
Wet Abrasion	:	Excellent
Dry Abrasion	:	Excellent
Standard	:	EN ISO 10325
Length	:	100-200 m Plastic/Wooden Spool or Coil

Other Colours & Larger Diameters Upon Request

DIA (mm)	Weight (kg/100m)	B.Load (kgf) SK78	B.Load (kgf) SK99	DIA (inch)	Weight (lbs/100ft)	B.Load (lbs) SK78	B.Load (lbs) SK99
2	0,25	490	580	3/32"	0,17	1.078	1.276
3	0,50	1.030	1.220	1/8"	0,34	2.266	2.684
4	1,00	1.830	2.160	5/32"	0,67	4.026	4.752
5	1,50	2.910	3.430	3/16"	1,01	6.402	7.546
6	2,00	4.390	5.180	1/4"	1,34	9.658	11.396
8	3,75	7.570	8.930	5/16"	2,52	16.654	19.646

*Unspliced Break Load (All Tests are in Accordance with ISO 2307)



DYNE K[®] EXTREME ▲ DINGHY LINES



DINGHY ROCK V[®] MIX

APPLICATIONS

Main Halyard

See Page 47

BENEFITS / FEATURES

Good Performance in Jammers
 High Breaking Load
 Extremely Low Stretch
 Easy to Splice

SPECIFICATIONS

Material	:	Cover: HT Polyester Fiber Core: Coated Vectran [®] Fiber
Specific Gravity	:	Approx. 1,38 kg/dm ³
Construction	:	Cover: 20-24 Plaited, Core: 12 Plaited
UV Resistance	:	Poor
Chemical Resistance	:	Good
Melting Point	:	256°C
Critical Temperature	:	170°C
Working Stretch	:	<1%
Fiber Water Absorption	:	Approx. %1-2
Wet Abrasion	:	Good
Length	:	100-200 m Plastic/Wooden Spool

Other Colours & Larger Diameters Upon Request

DIA (mm)	Weight (kg/100m)	B.Load (kgf)	DIA (inch)	Weight (lbs/100ft)	B.Load (lbs)
3	1,10	500	1/8"	0,74	1.100
4	1,30	750	5/32"	0,87	1.650
5	1,85	1.000	3/16"	1,24	2.200
6	2,85	1.500	1/4"	1,92	3.300
7	3,70	2.000	9/32"	2,49	4.400

*Unspliced Break Load (All Tests are in Accordance with ISO 2307)



DINGHY ROCK V[®] MIX ▲ DINGHY LINES



DINGHY ROCK D® MIX TP

APPLICATIONS

Main Sheet

See Page 47

BENEFITS / FEATURES

- Good Grip on Winches
- Very Good Performance in Jammers
- Very Good Heat Resistance
- Low Stretch
- Easy to Splice

SPECIFICATIONS

Material	:	Cover: Technora® & HT Polyester Fiber Core: Coated Dyneema® SK 78 Fiber
Specific Gravity	:	0,99-1,20 kg/dm ³
Construction	:	Cover: 20-24 Plaited, Core: 16 Plaited
UV Resistance	:	Sufficient
Chemical Resistance	:	Excellent
Melting Point	:	147-256°C
Critical Temperature	:	65°C
Working Stretch	:	<1,5%
Fiber Water Absorption:	:	Approx. %1-2
Wet Abrasion	:	Excellent
Length	:	100-200 m Plastic Spool

Other Colours & Larger Diameters Upon Request

DIA (mm)	Weight (kg/100m)	B.Load (kgf)	DIA (inch)	Weight (lbs/100ft)	B.Load (lbs)
4	1,25	900	5/32"	0,84	1.980
5	1,70	1.200	3/16"	1,14	2.640
6	2,60	1.800	1/4"	1,75	3.960
7	3,45	2.700	9/32"	2,32	5.940

*Unspliced Break Load (All Tests are in Accordance with ISO 2307)

DINGHY ROCK D® MIX DT

APPLICATIONS

Main Sheet

See Page 47

BENEFITS / FEATURES

- Excellent Grip on Winches
- Good Heat Resistance
- Low Stretch
- Easy to Splice

SPECIFICATIONS

Material	:	Cover: %50 Technora® Fiber %50 Dyneema® SK 78 Fiber Core: Coated Dyneema® SK 78 Fiber
Specific Gravity	:	0,99-1,20 kg/dm ³
Construction	:	Cover: 20-24 Plaited, Core: 16 Plaited
UV Resistance	:	Good
Chemical Resistance	:	Excellent
Melting Point	:	147-256°C
Critical Temperature	:	65°C
Working Stretch	:	<1,5%
Fiber Water Absorption:	:	Approx. %0-1
Wet Abrasion	:	Excellent
Length	:	100-200 m Plastic Spool

Other Colours & Larger Diameters Upon Request

DIA (mm)	Weight (kg/100m)	B.Load (kgf)	DIA (inch)	Weight (lbs/100ft)	B.Load (lbs)
4	1,45	900	5/32"	0,97	1.980
5	1,85	1.200	3/16"	1,24	2.640
6	2,45	1.800	1/4"	1,65	3.960
7	3,20	2.700	9/32"	2,15	5.940

*Unspliced Break Load (All Tests are in Accordance with ISO 2307)

DINGHY RACING HAWK

APPLICATIONS

Reefing Lines

See Page 47

BENEFITS / FEATURES

Very Good Performance in The Clamps
 Low Stretch
 Lightweight
 Easy To Splice
 High Breaking Load

SPECIFICATIONS

Material : Cover: Dyneema® SK 78 & HT Polyamide Fiber
 Core: Coated Dyneema® SK 78 & PPM Fiber
 Specific Gravity : 0,99-1,10 kg/dm³
 Construction : Cover: 16 Plaited, Core: 12 Plaited
 UV Resistance : Very Good
 Chemical Resistance : Good
 Melting Point : 147°C
 Critical Temperature : 65°C
 Working Stretch : <2%
 Fiber Water Absorption: Approx. %0-1
 Wet Abrasion : Excellent
 Length : 100-200 m Plastic Spool

Other Colours & Larger Diameters Upon Request

DIA (mm)	Weight (kg/100m)	B.Load (kgf)	DIA (inch)	Weight (lbs/100ft)	B.Load (lbs)
5	1,25	475	3/16"	0,84	1.045
6	1,90	900	1/4"	1,28	1.980
8	3,95	1.400	5/16"	2,65	3.080
10	5,60	3.000	3/8"	3,76	6.600
12	6,85	4.500	1/2"	4,60	9.900

*Unspliced Break Load (All Tests are in Accordance with ISO 2307)

ROCK D® MIX

APPLICATIONS

Reefing Lines

See Page 47

BENEFITS / FEATURES

Good Performance in Jammers
 Low Stretch
 Easy to Splice

SPECIFICATIONS

Material : Cover: HT Polyester Fiber
 Core: Coated Dyneema® SK 78 Fiber
 Specific Gravity : 0,99-1,20 kg/dm³
 Construction : Cover: 20-24 Plaited, Core: 16 Plaited
 UV Resistance : Excellent
 Chemical Resistance : Good
 Melting Point : 147-256°C
 Critical Temperature : 65°C
 Working Stretch : <1,5%
 Fiber Water Absorption: Approx. %0-1
 Wet Abrasion : Good
 Length : 100-200 m Plastic Spool

Other Colours & Larger Diameters Upon Request

DIA (mm)	Weight (kg/100m)	B.Load (kgf)	DIA (inch)	Weight (lbs/100ft)	B.Load (lbs)
3	0,95	600	1/8"	0,64	1.320
4	1,10	900	5/32"	0,74	1.980
5	1,55	1.200	3/16"	1,04	2.640
6	2,45	1.800	1/4"	1,65	3.960
7	3,30	2.700	9/32"	2,22	5.940

*Unspliced Break Load (All Tests are in Accordance with ISO 2307)



DINGHY RACING HAWK ▲ DINGHY LINES

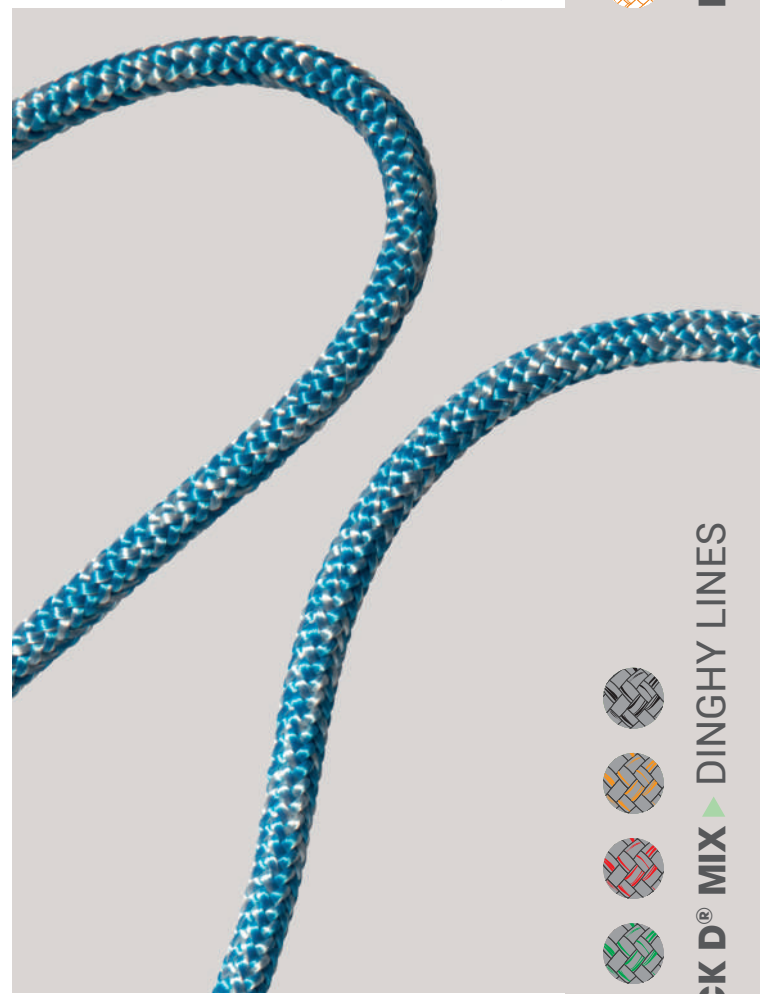

ROCK D® MIX ▲ DINGHY LINES



RACING ROCKET MIX TP

APPLICATIONS

Main Sheet
See Page 47

BENEFITS / FEATURES

Excellent Grip on Winches
Excellent Heat Resistance
Excellent Abrasion Resistance
Low Stretch
Easy to Splice

SPECIFICATIONS

Material : Cover: Technora® & HT Polyester Fiber
Core: Coated Dyneema® SK 78 Fiber
Specific Gravity : 1,10 kg/dm³
Construction : Cover: 16-20 Plaited, Core: 12 Plaited
UV Resistance : Sufficient
Chemical Resistance : Excellent
Melting Point : 147-256°C
Critical Temperature : 65°C
Working Stretch : <1,5%
Fiber Water Absorption: Approx. %1-2
Wet Abrasion : Excellent
Length : 100-200 m Plastic Spool

Other Colours & Larger Diameters Upon Request

DIA (mm)	Weight (kg/100m)	B.Load (kgf)	DIA (inch)	Weight (lbs/100ft)	B.Load (lbs)
6	3,25	2.050	1/4"	2,18	4.510
7	4,40	3.000	9/32"	2,96	6.600
8	5,30	4.100	5/16"	3,56	9.020
10	7,40	6.000	3/8"	4,97	13.200

*Unspliced Break Load (All Tests are in Accordance with ISO 2307)

RACING SUN MIX

APPLICATIONS

Main Sheet
Main Halyard
See Page 47

BENEFITS / FEATURES

Very Good Performance on Cleats
Very Good Abrasion Resistance
Low Stretch
Easy to Splice

SPECIFICATIONS

Material : Cover: Dyneema SK 78 & HT Polyester & Texturized Polyamide Fiber
Core: Dyneema® SK 78 Fiber
Specific Gravity : 1,04-1,07 kg/dm³
Construction : Cover: 20-24-32 Plaited, Core: 12 Plaited
UV Resistance : Excellent
Chemical Resistance : Good
Melting Point : 147-256°C
Critical Temperature : 65°C
Working Stretch : <1,5%
Fiber Water Absorption: Approx. %0-1
Wet Abrasion : Excellent
Length : 100-200 m Plastic Spool

Other Colours & Larger Diameters Upon Request

DIA (mm)	Weight (kg/100m)	B.Load (kgf)	DIA (inch)	Weight (lbs/100ft)	B.Load (lbs)
5	1,70	1.300	3/16"	1,14	2.860
6	2,35	2.050	1/4"	1,58	4.510
7	3,10	3.000	9/32"	2,08	6.600
8	4,00	4.100	5/16"	2,69	9.020
10	5,20	6.000	3/8"	3,49	13.200

*Unspliced Break Load (All Tests are in Accordance with ISO 2307)

DINGHY FLY MIX



APPLICATIONS

Main Sheet

See Page 47

BENEFITS / FEATURES

Lightweight
Very Good Abrasion Resistance
Very Good Grip
Easy to Splice

SPECIFICATIONS

Material	: Cover: Dyneema® SK 78 & HT Polyester & Texturized Polyamide Fiber Core: HT Polypropylene
Specific Gravity	: 1,01-1,03 kg/dm³
Construction	: Cover: 20-24 Plaited, Core: 12 Plaited
UV Resistance	: Excellent
Chemical Resistance	: Good
Melting Point	: 147°-256°C
Critical Temperature	: 65°C
Working Stretch	: <6%
Fiber Water Absorption:	Approx. %0-1
Wet Abrasion	: Excellent
Length	: 100-200 m Plastic Spool

Other Colours & Larger Diameters Upon Request

DIA (mm)	Weight (kg/100m)	B.Load (kgf)	DIA (inch)	Weight (lbs/100ft)	B.Load (lbs)
5	1,50	590	3/16"	1,01	1.298
6	2,10	850	1/4"	1,41	1.870
7	2,80	1.150	9/32"	1,88	2.530
8	3,30	1.450	5/16"	2,22	3.190

*Unspliced Break Load (All Tests are in Accordance with ISO 2307)

DINGHY PILOT MIX

APPLICATIONS

Main Sheet
Main Halyard
Control Lines

See Page 47

BENEFITS / FEATURES

Low Stretch
Very Good Abrasion Resistance
Very Good Grip
Easy to Splice

SPECIFICATIONS

Material	: Cover: HT Polyester & Texturized Polyamide Fiber Core: HT Polyester Fiber
Specific Gravity	: 1,22-1,24 kg/dm³
Construction	: Cover: 20-24 Plaited, Core: 8 Plaited
UV Resistance	: Excellent
Chemical Resistance	: Good
Melting Point	: 165-256°C
Critical Temperature	: 80°C
Working Stretch	: <5%
Fiber Water Absorption:	Approx. %1-2
Wet Abrasion	: Good
Length	: 100-200 m Plastic Spool

Other Colours & Larger Diameters Upon Request

DIA (mm)	Weight (kg/100m)	B.Load (kgf)	DIA (inch)	Weight (lbs/100ft)	B.Load (lbs)
6	2,80	850	1/4"	1,88	1.870
8	4,80	1.500	5/16"	3,23	3.300
10	7,60	2.300	3/8"	5,11	5.060
12	10,80	3.500	1/2"	7,26	7.700

*Unspliced Break Load (All Tests are in Accordance with ISO 2307)

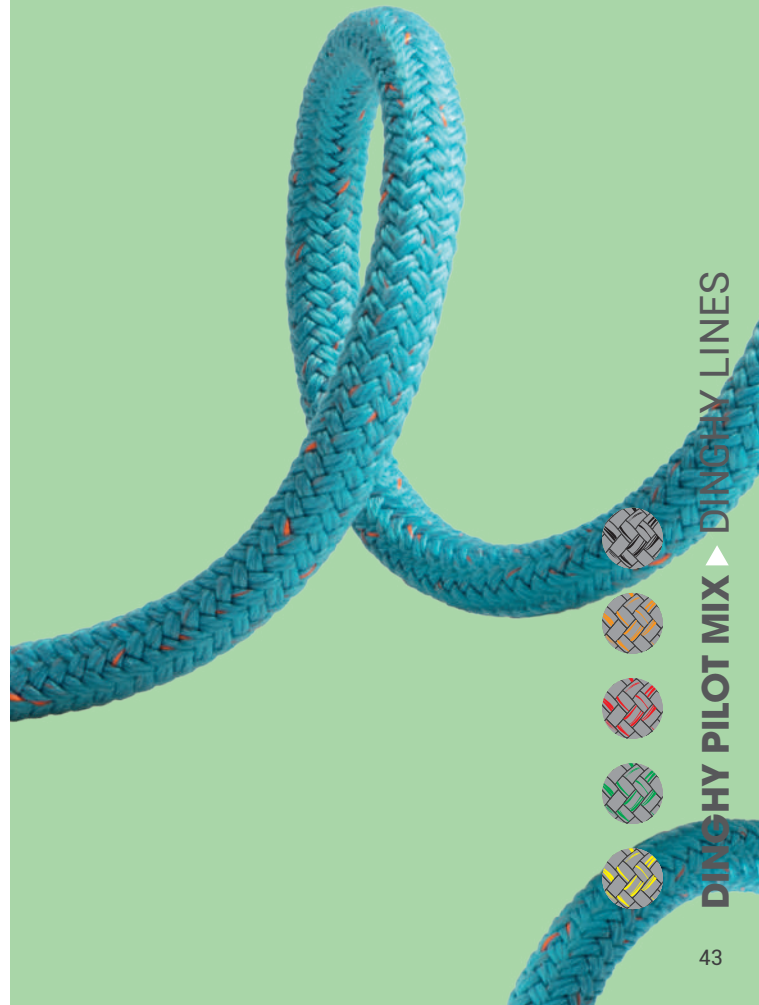

DINGHY FLY MIX ▲ DINGHY LINES



DINGHY PILOT MIX ▲ DINGHY LINES

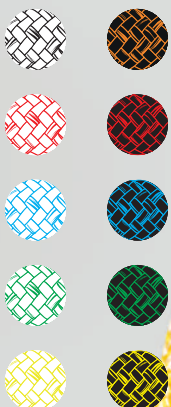

ROCK SOFT-D



APPLICATIONS

Main Sheet
See Page 47

BENEFITS / FEATURES

Very Suitable for Jammers
Comfortable Handling
Low Stretch
Lightweight
Excellent Dinghy Sheet

SPECIFICATIONS

Material	:	Blended Dyneema® SK 78 & Polyester Staple Fiber
Specific Gravity	:	0,99-1,20 kg/dm ³
Construction	:	8 Plaited (Hollow Braid)
UV Resistance	:	Excellent
Chemical Resistance	:	Good
Melting Point	:	147°C
Critical Temperature	:	65°C
Working Stretch	:	<2%
Fiber Water Absorption	:	Approx. %0-1
Wet Abrasion	:	Good
Length	:	100-200 m Plastic Spool

Other Colours & Larger Diameters Upon Request

DIA (mm)	Weight (kg/100m)	B.Load (kgf)	DIA (inch)	Weight (lbs/100ft)	B.Load (lbs)
4	1,20	500	5/32"	0,81	1.100
5	1,55	750	3/16"	1,04	1.650
6	1,95	1.000	1/4"	1,31	2.200
7	2,75	1.250	9/32"	1,85	2.750

*Unspliced Break Load (All Tests are in Accordance with ISO 2307)

LUPES® LS MIX

APPLICATIONS

Main Halyard
See Page 47

BENEFITS / FEATURES

Easy to Splice
Very Long Service Life
High Breaking Load
Shares the Load Equally Between Cover and Core
Stretches Less Than the Standard Polyester

SPECIFICATIONS

Material	:	Cover: HT Polyester Fiber Core: Coated HT Polyester Fiber
Specific Gravity	:	1,38 kg/dm ³
Construction	:	Cover: 24 Plaited, Core: 12 Plaited
UV Resistance	:	Excellent
Chemical Resistance	:	Good
Melting Point	:	256°C
Critical Temperature	:	170°C
Working Stretch	:	<4%
Fiber Water Absorption	:	Approx. %1-2
Wet Abrasion	:	Good
Length	:	100-200 m Plastic Spool

Other Colours & Larger Diameters Upon Request

DIA (mm)	Weight (kg/100m)	B.Load (kgf)	DIA (inch)	Weight (lbs/100ft)	B.Load (lbs)
6	3,10	1.200	1/4"	2,08	2.640
8	5,25	1.700	5/16"	3,53	3.740
10	8,10	2.560	3/8"	5,44	5.632
12	11,35	3.600	1/2"	7,63	7.920

*Unspliced Break Load (All Tests are in Accordance with ISO 2307)

LUPES® CORD

APPLICATIONS

Control Line

See Page 47

BENEFITS / FEATURES

Outstanding Flexibility
 Cost-Efficient
 Low Stretch

SPECIFICATIONS

Material	:	Cover: HT Polyester Fiber Core: HT Polyester Fiber
Specific Gravity	:	1,38 kg/dm ³
Construction	:	Cover: 16 Plaited, Core: Parallel Braided
UV Resistance	:	Excellent
Chemical Resistance	:	Good
Melting Point	:	256°C
Critical Temperature	:	170°C
Working Stretch	:	<5%
Fiber Water Absorption	:	Approx. %1-2
Wet Abrasion	:	Good
Length	:	100-200 m Plastic Spool

Other Colours & Larger Diameters Upon Request

DIA (mm)	Weight (kg/100m)	B.Load (kgf)	DIA (inch)	Weight (lbs/100ft)	B.Load (lbs)
3	0,85	180	1/8"	0,57	396
4	1,20	300	5/32"	0,81	660
5	1,95	460	3/16"	1,31	1.012
6	2,70	660	1/4"	1,81	1.452

*Unspliced Break Load (All Tests are in Accordance with ISO 2307)



LUPES® CORD ▲ DINGHY LINES

LUPP® CORD

APPLICATIONS

Control Line

See Page 47

BENEFITS / FEATURES

Outstanding Flexibility
 Economically Priced
 Low Stretch
 Buoyant

SPECIFICATIONS

Material	:	Cover: HT Polypropylene Fiber Core: HT Polypropylene Fiber
Specific Gravity	:	0,91 kg/dm ³
Construction	:	Cover: 16 Plaited, Core: Parallel Braided
UV Resistance	:	Sufficient
Chemical Resistance	:	Very Good
Melting Point	:	165°C
Critical Temperature	:	80°C
Working Stretch	:	<6%
Fiber Water Absorption	:	None
Wet Abrasion	:	Sufficient
Length	:	100-200 m Plastic Spool

Other Colours & Larger Diameters Upon Request

DIA (mm)	Weight (kg/100m)	B.Load (kgf)	DIA (inch)	Weight (lbs/100ft)	B.Load (lbs)
4	0,70	250	5/32"	0,47	550
5	1,20	400	3/16"	0,81	880
6	1,60	550	1/4"	1,08	1.210

*Unspliced Break Load (All Tests are in Accordance with ISO 2307)

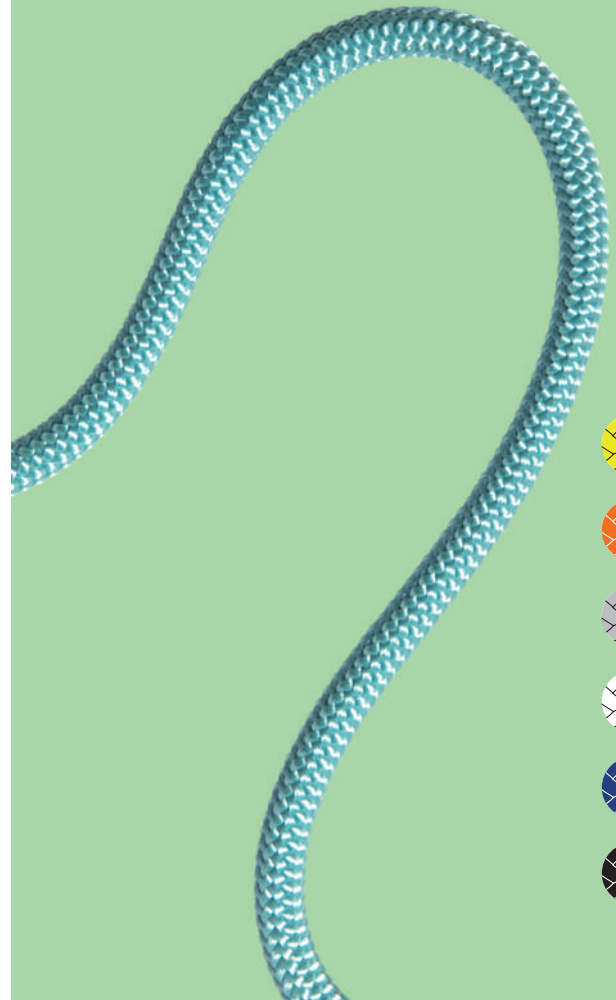

LUPP® CORD ▲ DINGHY LINES



ROPE APPLICATIONS FOR DINGHY LINES

ROPE NAMES	HALYARDS					SHEETS				CONTROL LINES									
	PAGE	MAIN	GENOA	SPI HALYARD	REEFING LINES	MAIN	GENOA	SPINNAKER	SPI POLE UPHAUL	SPI POLE FOREGUY	ROLLER REEFING LINE	TOPMAST BACKSTAY	TRAPEZ LINE	BOOM VANG	CUNNINGHAM	MAIN OUTHAUL	GENOA CAR TRAVELLER	MAIN CAR TRAVELLER	CONTROL LINE
DYNE K® EXTREME	39	✓	✓	✓	✓	✓	✓	✓	✓			✓		✓					
DINGHY ROCK V® MIX	39					✓	✓	✓	✓			✓		✓					
DINGHY ROCK D® MIX TP	40					✓	✓	✓	✓			✓		✓					
DINGHY ROCK D® MIX DT	40					✓	✓	✓	✓			✓		✓					
DINGHY RACING HAWK	41	✓	✓	✓	✓	✓	✓	✓	✓	✓	✓	✓	✓	✓	✓	✓	✓	✓	✓
ROCK D® MIX	41	✓	✓	✓	✓		✓			✓	✓	✓	✓	✓	✓	✓	✓	✓	✓
RACING ROCKET MIX TP	42					✓	✓	✓	✓			✓		✓					
RACING SUN MIX	42					✓	✓	✓	✓			✓		✓					
DINGHY FLY MIX	43					✓	✓	✓	✓										
DINGHY PILOT MIX	43	✓	✓	✓	✓	✓	✓	✓	✓	✓	✓	✓	✓	✓	✓	✓	✓	✓	✓
ROCK® SOFT D	44	✓	✓			✓			✓						✓	✓			
LUPES® LS MIX	44	✓	✓	✓	✓	✓	✓	✓	✓	✓	✓	✓	✓	✓	✓	✓	✓	✓	✓
LUPES® CORD	45	✓	✓	✓	✓	✓	✓	✓	✓			✓		✓					
LUPP® CORD	45						✓	✓				✓							



MOORING LINES

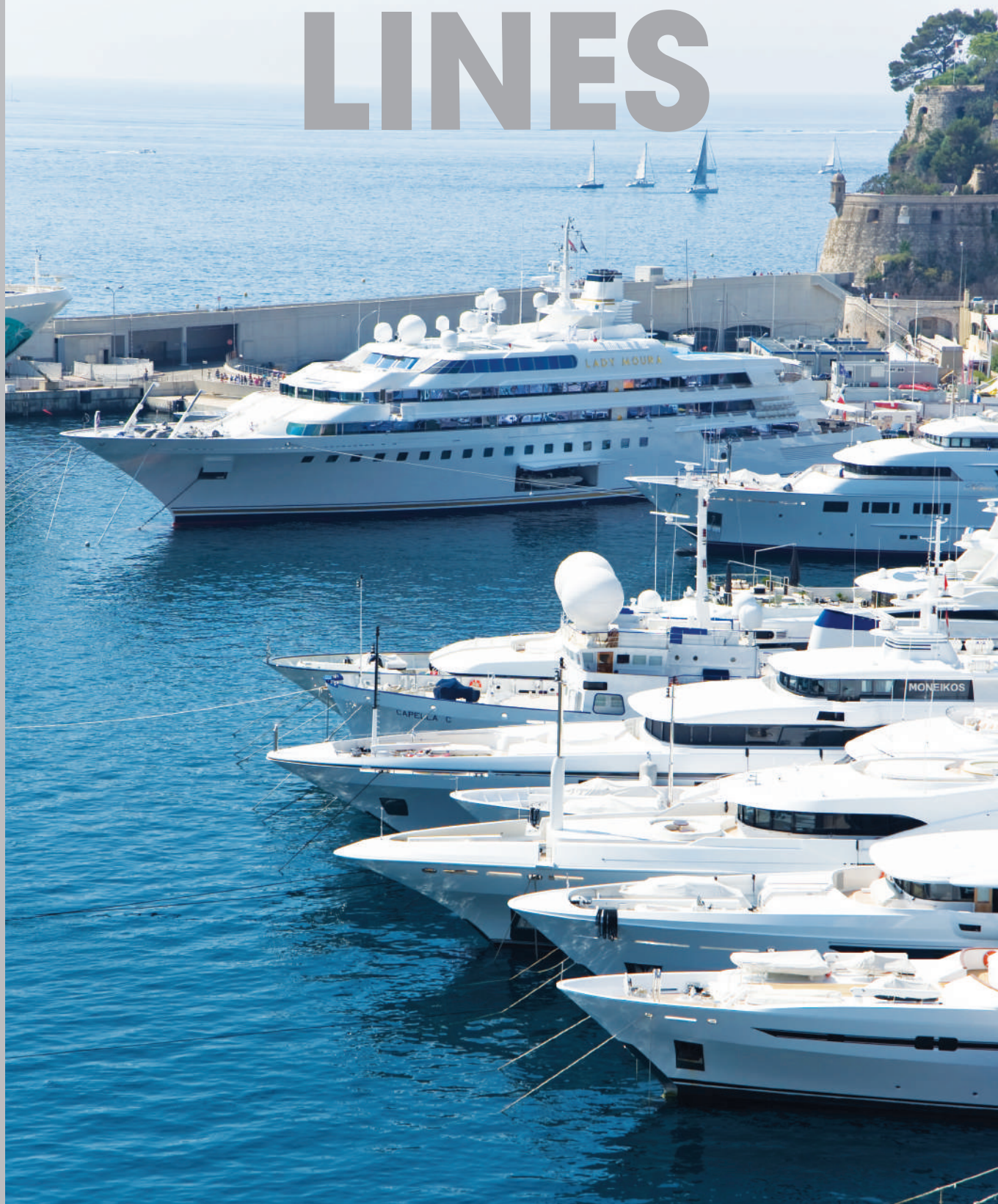

LUPES® VIPERA

APPLICATIONS

Dock Line
Anchor Line
Towing Line

See Page 74

BENEFITS / FEATURES

Does not Harden
Does not Kink
Soft Hand
Durable
Flexible Cover
High Breaking Load
Excellent Abrasion Resistance



SPECIFICATIONS

Material	: 100% HT Polyester Fiber
Type	: -
Specific Gravity	: 1,38 kg/dm³
Construction	: Cover: 16-20-24 Plaited Core: 16 Plaited
UV Resistance	: Excellent
Chemical Resistance	: Good
Melting Point	: 256°C
Critical Temperature	: 170°C
Elongation at Break	: Approx. %15
Fiber Water Absorption	: Approx. %1-2
Wet Abrasion	: Good
Dry Abrasion	: Good
Standart	: EN ISO 10547
Length	: 100-200 m Plastic/Wooden Spool or Coil

Other Colours on Request

DIA (mm)	Weight (kg/100m)	Min. B.Load (kgf)	DIA (inch)	Weight (lbs/100ft)	Min. B.Load (lbs)
8	4,85	1.320	5/16"	3,26	2.904
10	7,45	2.050	3/8"	5,01	4.510
12	11,00	2.900	1/2"	7,39	6.380
14	14,80	3.910	9/16"	9,95	8.602
16	19,40	5.070	5/8"	13,04	11.154
18	24,80	6.370	3/4"	16,67	14.014
20	30,40	7.800	13/16"	20,43	17.160
22	36,85	9.380	7/8"	24,76	20.636
24	43,65	11.110	1"	29,33	24.442
26	51,25	14.385	1-1/16"	34,44	31.647
28	59,40	16.630	1-1/8"	39,93	36.586

*Unspliced Break Load (All Tests are in Accordance with ISO 2307)



LUPES® VIPERA ▲ MOORING LINES

CLASSIC
LOOK



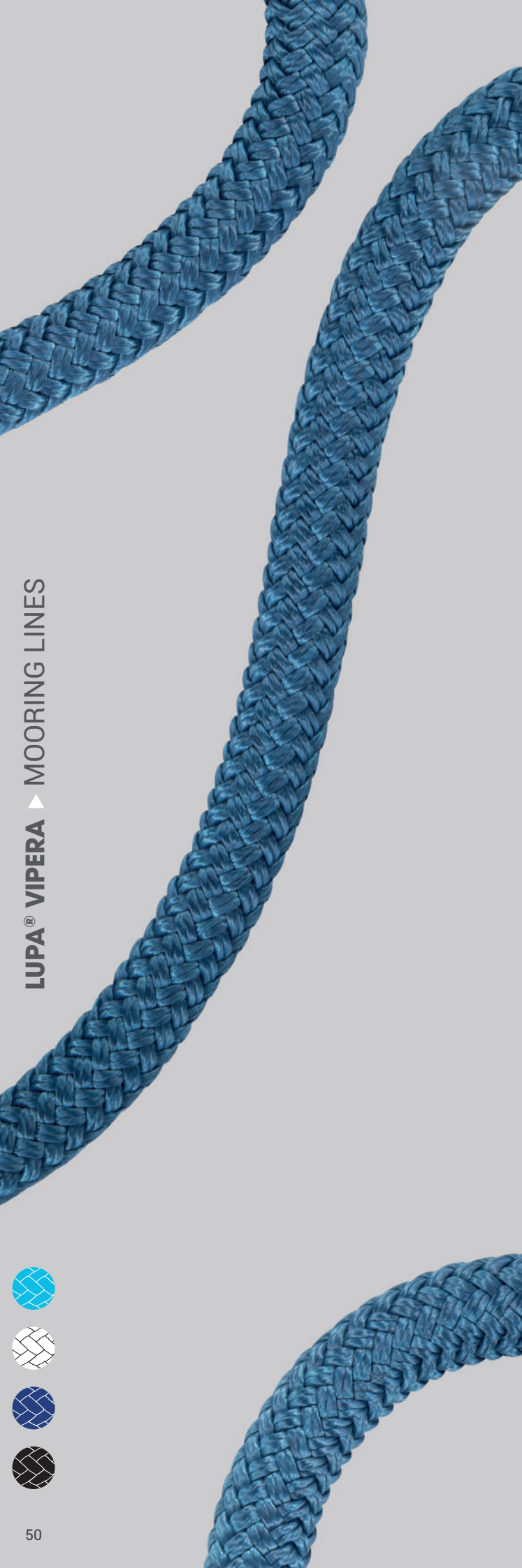

LUPA® VIPERA

APPLICATIONS

- Dock Line
- Anchor Line
- Towing Line

See Page 74

BENEFITS / FEATURES

- Does not Harden
- Does not Kink
- Soft Hand
- Durable
- Flexible Cover
- High Breaking Load
- Excellent Shock Absorption



SPECIFICATIONS

Material	:	100% HT Polyamide Fiber
Type	:	-
Specific Gravity	:	1,14 kg/dm ³
Construction	:	Cover: 16-20-24 Plaited Core: 16 Plaited
UV Resistance	:	Very Good
Chemical Resistance	:	Good
Melting Point	:	218°C
Critical Temperature	:	130°C
Elongation at Break	:	Approx. %30
Fiber Water Absorption	:	Approx. %3-4
Wet Abrasion	:	Sufficient
Dry Abrasion	:	Good
Standard	:	EN ISO 10554
Length	:	100-200 m Plastic/Wooden Spool or Coil

Other Colours on Request

DIA (mm)	Weight (kg/100m)	Min. B.Load (kgf)	DIA (inch)	Weight (lbs/100ft)	Min. B.Load (lbs)
8	4,10	1.420	5/16"	2,76	3.124
10	6,20	2.220	3/8"	4,17	4.884
12	9,20	3.190	1/2"	6,18	7.018
14	12,40	4.330	9/16"	8,33	9.526
16	16,25	5.640	5/8"	10,92	12.408
18	20,40	7.120	3/4"	13,71	15.664
20	25,50	8.790	13/16"	17,14	19.338
22	31,00	10.600	7/8"	20,83	23.320
24	36,65	12.640	1"	24,63	27.808
26	43,00	14.790	1-1/16"	28,90	32.538
28	49,75	17.130	1-1/8"	33,43	37.686

*Unspliced Break Load (All Tests are in Accordance with ISO 2307)



LUPP® VIPERA

APPLICATIONS

Dock Line
Towing Line
See Page 74

BENEFITS / FEATURES

Does not Harden
Does not Kink
Soft Hand
Durable
Flexible Cover
Economically Priced
Buoyant



SPECIFICATIONS

Material	: 100% HT Polypropylene Fiber
Type	: -
Specific Gravity	: 0,91 kg/dm ³
Construction	: Cover: 16-20-24 Plaited Core: 16 Plaited
UV Resistance	: Sufficient
Chemical Resistance	: Very Good
Melting Point	: 165°C
Critical Temperature	: 80°C
Elongation at Break	: Approx. %23
Fiber Water Absorption	: None
Wet Abrasion	: Sufficient
Dry Abrasion	: Sufficient
Standard	: -
Length	: 100-200 m Plastic/Wooden Spool or Coil

Other Colours on Request

DIA (mm)	Weight (kg/100m)	Min. B.Load (kgf)	DIA (inch)	Weight (lbs/100ft)	Min. B.Load (lbs)
8	2,90	1.000	5/16"	1,95	2.200
10	4,20	1.510	3/8"	2,82	3.322
12	6,20	2.100	1/2"	4,17	4.620
14	9,10	3.000	9/16"	6,12	6.600
16	10,90	4.000	5/8"	7,32	8.800
18	14,50	4.975	3/4"	9,74	10.945
20	18,15	6.045	13/16"	12,20	13.299
22	21,75	7.200	7/8"	14,62	15.840
24	25,90	8.425	1"	17,40	18.535
26	30,35	9.765	1-1/16"	20,40	21.483
28	34,95	12.000	1-1/8"	23,49	26.400

*Unspliced Break Load (All Tests are in Accordance with ISO 2307)



LUPP® VIPERA ▲ MOORING LINES

CLASSIC LOOK



DYNE VIPERA® COATED

APPLICATIONS

Winch Line
Towing Line
Mooring Line

See Page 74

BENEFITS / FEATURES

Excellent Breaking Load
Durable
Very Low Stretch
Firm and Round
Does not Kink



SPECIFICATIONS

Material	: Cover: HT Polyester Fiber Core: Coated Dyneema® SK 75/78 Fiber
Specific Gravity	: 1,00-1,20 kg/dm ³
Construction	: Cover: 24-32 Plaited Core: 12 Plaited
UV Resistance	: Excellent
Chemical Resistance	: Good
Melting Point	: 147-256°C
Critical Temperature	: 65°C
Elongation at Break	: <1%
Fiber Water Absorption	: Approx. %0-1
Wet Abrasion	: Good
Dry Abrasion	: Good
Standard	: -
Length	: Upon Request

Other Colours & Larger Diameters Upon Request

DIA (mm)	Weight (kg/100m)	B.Load (kgf) Unspliced	B.Load (kgf) Spliced	DIA (inch)	Weight (lbs/100ft)	B.Load (lbs) Unspliced	B.Load (lbs) Spliced
16	20,50	15.000	13.640	5/8"	13,78	32.990	30.000
18	25,00	19.000	17.270	3/4"	16,80	41.800	37.990
20	30,50	22.500	20.450	13/16"	20,50	49.500	44.990
22	35,80	26.250	23.860	7/8"	24,06	57.750	52.490
24	40,50	30.000	27.270	1"	27,22	66.000	59.990
26	46,00	33.750	30.680	1-1/16"	30,91	74.250	67.490
28	56,00	41.250	37.500	1-1/8"	37,63	90.750	82.500
30	62,30	45.000	40.910	1-1/4"	41,87	99.000	90.000
32	70,20	52.500	47.730	1-5/16"	47,17	115.500	105.000
36	85,50	66.000	60.000	1-1/2"	57,46	145.200	132.000
40	103,00	78.000	70.910	1-5/8"	69,22	171.600	156.000

*Spliced Break Load (All Tests are in Accordance with ISO 2307)



DYNE VIPERA® UNCOATED

APPLICATIONS

Winch Line
Towing Line
Mooring Line

See Page 74

BENEFITS / FEATURES

Excellent Breaking Load
Durable
Low Stretch
Firm and Round
Does not Kink
Flexible



SPECIFICATIONS

Material	: Cover: HT Polyester Fiber Core: Uncoated Dyneema® SK 75/78 Fiber
Specific Gravity	: 1,00-1,20 kg/dm³
Construction	: Cover: 24-32 Plaited Core: 12 Plaited
UV Resistance	: Excellent
Chemical Resistance	: Good
Melting Point	: 147-256°C
Critical Temperature	: 65°C
Elongation at Break	: <1%
Fiber Water Absorption	: Approx. %0-1
Wet Abrasion	: Good
Dry Abrasion	: Good
Standard	: -
Length	: Upon Request

Other Colours & Larger Diameters Upon Request

DIA (mm)	Weight (kg/100m)	B.Load (kgf) Unspliced	B.Load (kgf) Spliced	DIA (inch)	Weight (lbs/100ft)	B.Load (lbs) Unspliced	B.Load (lbs) Spliced
16	20,50	15.000	13.640	5/8"	13,78	32.990	30.000
18	25,00	19.000	17.270	3/4"	16,80	41.800	37.990
20	30,50	22.500	20.450	13/16"	20,50	49.500	44.990
22	35,80	26.250	23.860	7/8"	24,06	57.750	52.490
24	40,50	30.000	27.270	1"	27,22	66.000	59.990
26	46,00	33.750	30.680	1-1/16"	30,91	74.250	67.490
28	56,00	41.250	37.500	1-1/8"	37,63	90.750	82.500
30	62,30	45.000	40.910	1-1/4"	41,87	99.000	90.000
32	70,20	52.500	47.730	1-5/16"	47,17	115.500	105.000
36	85,50	66.000	60.000	1-1/2"	57,46	145.200	132.000
40	103,00	78.000	70.910	1-5/8"	69,22	171.600	156.000

*Spliced Break Load (All Tests are in Accordance with ISO 2307)



DYNE VIPERA® UNCOATED ▶ MOORING LINES



LUPES® VIPERA PREMIER

APPLICATIONS

- Dock Line
- Anchor Line
- Towing Line
- See Page 74

BENEFITS / FEATURES

- Does not Harden
- Does not Kink
- Soft Hand
- Durable
- Superior Chafe Cover
- High Breaking Load
- Excellent Abrasion Resistance



SPECIFICATIONS

- Material : 100% HT Polyester Fiber
- Type : -
- Specific Gravity : 1,38 kg/dm³
- Construction : Cover: 32 Plaited
Core: 12 Plaited
- UV Resistance : Excellent
- Chemical Resistance : Good
- Melting Point : 256°C
- Critical Temperature : 170°C
- Elongation at Break : Approx. %15
- Fiber Water Absorption : Approx. %1-2
- Wet Abrasion : Good
- Dry Abrasion : Good
- Standard : -
- Length : 100-200 m Wooden Spool or Coil

Other Colours on Request

DIA (mm)	Weight (kg/100m)	Min. B.Load (kgf)	DIA (inch)	Weight (lbs/100ft)	Min. B.Load (lbs)
30	68,35	19.000	1-1/4"	45,93	41.800
32	77,90	21.500	1-5/16"	52,35	47.300
34	89,05	24.250	1-3/8"	59,84	53.350
36	99,60	27.000	1-1/2"	66,93	59.400
38	109,45	30.000	1-9/16"	73,55	66.000
40	123,40	33.000	1-5/8"	82,92	72.600
42	133,60	36.500	1-11/16"	89,78	80.300
44	146,35	40.000	1-3/4"	98,35	88.000
46	162,65	43.500	1-13/16"	109,30	95.700
48	177,35	47.000	2"	119,18	103.400
56	238,10	63.000	2-1/4"	160,00	138.600

*Unspliced Break Load (All tests are in Accordance with ISO 2307)



LUPA[®] VIPERA PREMIER

APPLICATIONS

Dock Line
Anchor Line
Towing Line

See Page 74

BENEFITS / FEATURES

Does not Harden
Does not Kink
Soft Hand
Durable
Superior Chafe Cover
High Breaking Load
Excellent Shock Absorption



SPECIFICATIONS

Material	: 100% HT Polyamide Fiber
Type	: -
Specific Gravity	: 1,14 kg/dm ³
Construction	: Cover: 32 Plaited Core: 12 Plaited
UV Resistance	: Very Good
Chemical Resistance	: Good
Melting Point	: 218°C
Critical Temperature	: 130°C
Elongation at Break	: Approx. %30
Fiber Water Absorption	: Approx. %3-4
Wet Abrasion	: Sufficient
Dry Abrasion	: Good
Standard	: -
Length	: 100-200 m Wooden Spool or Coil

Other Colours on Request

DIA (mm)	Weight (kg/100m)	Min. B.Load (kgf)	DIA (inch)	Weight (lbs/100ft)	Min. B.Load (lbs)
30	55,60	19.700	1-1/4"	37,36	43.340
32	63,35	22.400	1-5/16"	42,57	49.280
34	72,45	25.300	1-3/8"	48,69	55.660
36	81,00	28.250	1-1/2"	54,43	62.150
38	89,05	31.500	1-9/16"	59,84	69.300
40	100,35	34.800	1-5/8"	67,43	76.560
42	108,65	38.400	1-11/16"	73,01	84.480
44	119,05	42.000	1-3/4"	80,00	92.400
46	132,35	46.000	1-13/16"	88,94	101.200
48	144,35	50.000	2"	97,00	110.000
56	191,50	67.800	2-1/4"	128,69	149.160

*Unspliced Break Load (All tests are in Accordance with ISO 2307)

LUPA[®] VIPERA PREMIER ▲ MOORING LINES





LUPP® VIPERA PREMIER

APPLICATIONS

- Dock Line
- Towing Line
- See Page 74

BENEFITS / FEATURES

- Does not Harden
- Does not Kink
- Soft Hand
- Superior Chafe Cover
- Economically Priced
- Buoyant



SPECIFICATIONS

Material	:	100% HT Polypropylene Fiber
Type	:	-
Specific Gravity	:	0,91 kg/dm ³
Construction	:	Cover: 32 Plaited Core: 12 Plaited
UV Resistance	:	Sufficient
Chemical Resistance	:	Very Good
Melting Point	:	165°C
Critical Temperature	:	80°C
Elongation at Break	:	Approx. %23
Fiber Water Absorption	:	None
Wet Abrasion	:	Sufficient
Dry Abrasion	:	Sufficient
Standard	:	-
Length	:	100-200 m Wooden Spool or Coil

Other Colours on Request

DIA (mm)	Weight (kg/100m)	Min. B.Load (kgf)	DIA (inch)	Weight (lbs/100ft)	Min. B.Load (lbs)
30	40,50	12.000	1-1/4"	27,22	26.400
32	47,95	13.200	1-5/16"	32,22	29.040
34	52,85	15.000	1-3/8"	35,52	33.000
36	60,85	16.000	1-1/2"	40,89	35.200
38	64,95	18.200	1-9/16"	43,65	40.040
40	73,20	20.500	1-5/8"	49,19	45.100
42	81,00	22.800	1-11/16"	54,43	50.160
44	86,90	25.000	1-3/4"	58,40	55.000
46	98,40	27.300	1-13/16"	66,12	60.060
48	105,45	29.600	2"	70,86	65.120
56	141,85	41.000	2-1/4"	95,32	90.200

*Unspliced Break Load (All tests are in Accordance with ISO 2307)

CLASSIC LOOK



LUPA® VIPERA USA

APPLICATIONS

Dock Line
Anchor Line
Towing Line

See Page 74

BENEFITS / FEATURES

Does not Harden
Does not Kink
Soft Hand
Durable
Flexible Cover
High Breaking Load
Excellent Shock Absorption



SPECIFICATIONS

Material : 100% HT Polyamide Fiber
Type : -
Specific Gravity : 1,14 kg/dm³
Construction : Cover: 24 Plaited
Core: 12 Plaited
UV Resistance : Very Good
Chemical Resistance : Good
Melting Point : 218°C
Critical Temperature : 130°C
Elongation at Break : Approx. %30
Fiber Water Absorption : Approx. %3-4
Wet Abrasion : Sufficient
Dry Abrasion : Good
Standard : -
Length : 100-200 m Wooden Spool or Coil

Other Colors & Larger Diameters Upon Request

DIA (mm)	Weight (kg/100m)	Min. B.Load (kgf)	DIA (inch)	Weight (lbs/100ft)	Min. B.Load (lbs)
18	22,50	9.586	3/4"	15,12	21.090
22	30,00	12.866	7/8"	20,16	28.305
24	40,00	16.902	1"	26,88	37.185
28	50,50	21.191	1-1/8"	33,94	46.620
30	59,25	25.580	1-1/4"	39,82	56.277
32	68,50	28.255	1-5/16"	46,03	62.160
36	89,00	36.580	1-1/2"	59,81	80.475
40	105,00	41.120	1-5/8"	70,56	90.465
42	117,00	44.400	1-11/16"	78,62	97.680

*Unspliced Break Load (All tests are in Accordance with ISO 2307)



LUPA® VIPERA USA ▲ MOORING LINES



LUPES® EUROPA

APPLICATIONS

Dock Line
Anchor Line
Towing Line

See Page 74

BENEFITS / FEATURES

Does not Harden
Does not Kink
Superior Soft Hand
Durable
Flexible Cover
High Breaking Load
Excellent Abrasion Resistance



SPECIFICATIONS

Material	:	100% HT Polyester Fiber
Type	:	-
Specific Gravity	:	1,38 kg/dm ³
Construction	:	Cover: 24 Plaited Core: 12 Plaited
UV Resistance	:	Excellent
Chemical Resistance	:	Good
Melting Point	:	256°C
Critical Temperature	:	170°C
Elongation at Break	:	Approx. %15
Fiber Water Absorption	:	Approx. %1-2
Wet Abrasion	:	Good
Dry Abrasion	:	Good
Standard	:	-
Length	:	100-200 m Wooden Spool or Coil

Other Colours on Request

DIA (mm)	Weight (kg/100m)	Min. B.Load (kgf)	DIA (inch)	Weight (lbs/100ft)	Min. B.Load (lbs)
24	41,50	11.500	1"	27,89	25.300
28	55,15	15.000	1-1/8"	37,06	33.000
32	73,20	20.000	1-5/16"	49,19	44.000
36	96,15	24.000	1-1/2"	64,61	52.800
40	114,20	28.500	1-5/8"	76,74	62.700

*Unspliced Break Load (All tests are in Accordance with ISO 2307)



LUPA® EUROPA

APPLICATIONS

Dock Line
Anchor Line
Towing Line

See Page 74

BENEFITS / FEATURES

Does not Harden
Does not Kink
Superior Soft Hand
Durable
Flexible Cover
High Breaking Load
Excellent Shock Absorption



SPECIFICATIONS

Material : 100% HT Polyamide Fiber
Type : -
Specific Gravity : 1,14 kg/dm³
Construction : Cover: 24 Plaited
Core: 12 Plaited
UV Resistance : Very Good
Chemical Resistance : Good
Melting Point : 218°C
Critical Temperature : 130°C
Elongation at Break : Approx. %30
Fiber Water Absorption : Approx. %3-4
Wet Abrasion : Sufficient
Dry Abrasion : Good
Standard : -
Length : 100-200 m Wooden Spool or Coil

Other Colours on Request

DIA (mm)	Weight (kg/100m)	Min. B.Load (kgf)	DIA (inch)	Weight (lbs/100ft)	Min. B.Load (lbs)
24	34,05	12.000	1"	22,88	26.400
28	45,25	16.000	1-1/8"	30,41	35.200
32	60,05	21.000	1-5/16"	40,35	46.200
36	78,85	25.500	1-1/2"	52,99	56.100
40	93,65	30.000	1-5/8"	62,93	66.000

*Unspliced Break Load (All tests are in Accordance with ISO 2307)

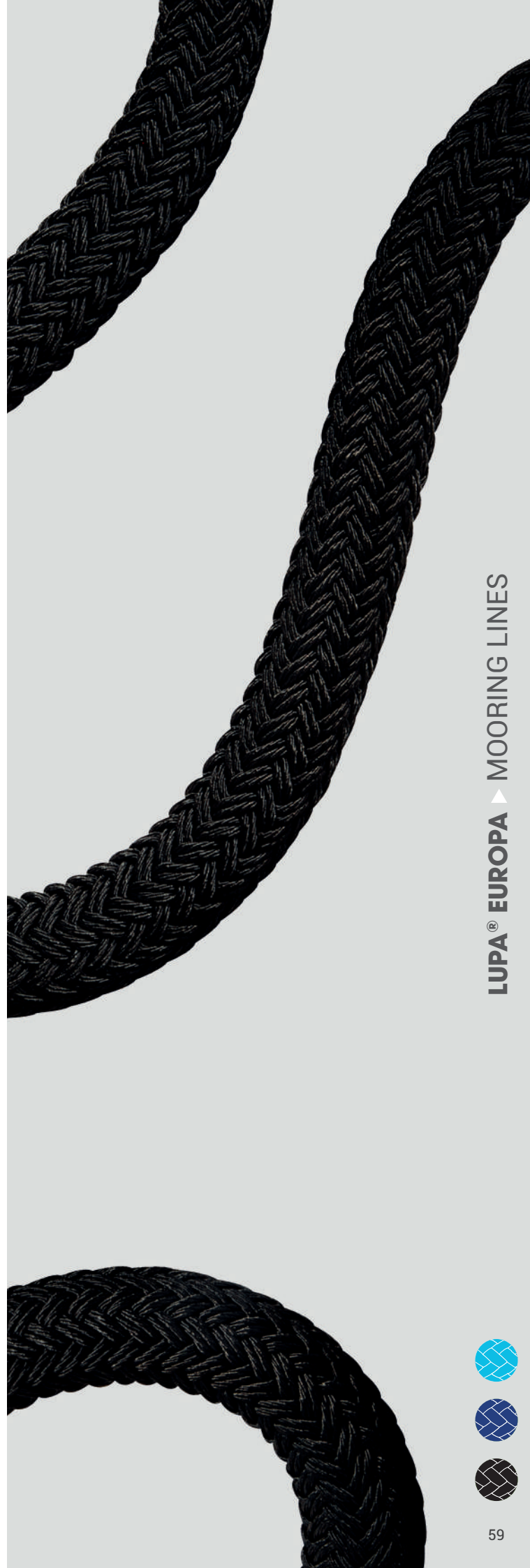

LUPA® EUROPA ▲ MOORING LINES





LUPES® ROUND ▶ MOORING LINES



CLASSIC LOOK



LUPES® ROUND

APPLICATIONS

Dock Line
Anchor Line
Towing Line

See Page 74

BENEFITS / FEATURES

Does not Harden
Does not Kink
Soft Hand
Durable
High Breaking Load
Easy to Splice
Excellent Abrasion Resistance

SPECIFICATIONS

Material	:	100% HT Polyester Fiber
Type	:	T
Specific Gravity	:	1,38 kg/dm ³
Construction	:	12 Strand Plaited
UV Resistance	:	Excellent
Chemical Resistance	:	Good
Melting Point	:	256°C
Critical Temperature	:	170°C
Elongation at Break	:	Approx. %15-20
Fiber Water Absorption	:	Approx. %1-2
Wet Abrasion	:	Good
Dry Abrasion	:	Good
Standard	:	EN ISO 1141
Length	:	100-200 m Wooden Spool or Coil

Other Colours on Request

DIA (mm)	Weight (kg/100m)	Min. B.Load (kgf)	DIA (inch)	Weight (lbs/100ft)	Min. B.Load (lbs)
18	27,15	7.640	3/4"	18,24	16.808
20	30,40	8.250	13/16"	20,43	18.150
22	36,70	10.000	7/8"	24,66	22.000
24	43,70	11.500	1"	29,37	25.300
26	51,20	13.500	1-1/16"	34,41	29.700
28	59,50	15.500	1-1/8"	39,98	34.100
30	68,30	17.750	1-1/4"	45,90	39.050
32	77,70	20.000	1-5/16"	52,21	44.000
34	88,00	22.500	1-3/8"	59,14	49.500
36	98,40	25.000	1-1/2"	66,12	55.000
38	109,70	29.000	1-9/16"	73,72	63.800
40	121,00	33.000	1-5/8"	81,31	72.600
42	134,00	36.250	1-11/16"	90,05	79.750
44	147,00	39.500	1-3/4"	98,78	86.900
46	161,00	42.750	1-13/16"	108,19	94.050
48	175,00	46.000	2"	117,60	101.200
52	205,00	54.000	2-1/8"	137,76	118.800
56	238,00	62.000	2-1/4"	159,94	136.400
60	273,00	71.000	2-1/2"	183,46	156.200
64	311,00	80.000	2-5/8"	208,99	176.000
72	393,00	100.000	3"	264,10	220.000
80	486,00	123.000	3-1/4"	326,59	270.600
88	588,00	148.000	3-5/8"	395,13	325.600
96	699,00	175.000	4"	469,73	385.000

*Unspliced Break Load (All tests are in Accordance with ISO 2307)

LUPA® ROUND

APPLICATIONS

Dock Line
Anchor Line
Towing Line

See Page 74

BENEFITS / FEATURES

Does not Harden
Does not Kink
Soft Hand
Durable
High Breaking Load
Easy to Splice
Excellent Shock Absorption

SPECIFICATIONS

Material	: 100% HT Polyamide Fiber
Type	: T
Specific Gravity	: 1,14 kg/dm ³
Construction	: 12 Strand Plaited
UV Resistance	: Very Good
Chemical Resistance	: Good
Melting Point	: 218°C
Critical Temperature	: 130°C
Elongation at Break	: Approx. %30-35
Fiber Water Absorption	: Approx. %3-4
Wet Abrasion	: Sufficient
Dry Abrasion	: Good
Standard	: EN ISO 1140
Length	: 100-200 m Wooden Spool or Coil

Other Colours on Request

DIA (mm)	Weight (kg/100m)	Min. B.Load (kgf)	DIA (inch)	Weight (lbs/100ft)	Min. B.Load (lbs)
18	23,00	8.000	3/4"	15,46	17.600
20	25,00	8.670	13/16"	16,80	19.074
22	30,50	10.300	7/8"	20,50	22.660
24	36,00	12.030	1"	24,19	26.466
26	42,50	14.500	1-1/16"	28,56	31.900
28	49,00	17.000	1-1/8"	32,93	37.400
30	56,00	19.000	1-1/4"	37,63	41.800
32	64,00	21.125	1-5/16"	43,01	46.475
34	72,50	24.310	1-3/8"	48,72	53.482
36	81,00	27.500	1-1/2"	54,43	60.500
38	90,50	30.750	1-9/16"	60,82	67.650
40	100,00	34.000	1-5/8"	67,20	74.800
42	110,50	37.500	1-11/16"	74,26	82.500
44	121,00	41.000	1-3/4"	81,31	90.200
46	132,50	44.500	1-13/16"	89,04	97.900
48	144,20	48.000	2"	96,90	105.600
52	170,00	58.000	2-1/8"	114,24	127.600
56	197,00	68.000	2-1/4"	132,38	149.600
60	226,00	76.250	2-1/2"	151,87	167.750
64	257,00	84.500	2-5/8"	172,70	185.900
72	325,00	110.000	3"	218,40	242.000
80	401,00	129.000	3-1/4"	269,47	283.800
88	486,00	152.000	3-5/8"	326,59	334.400
96	578,00	183.000	4"	388,41	402.600

*Unspliced Break Load (All tests are in Accordance with ISO 2307)



LUPA® ROUND ▲ MOORING LINES



LUPP® ROUND

APPLICATIONS

Dock Line
Towing Line
See Page 74

BENEFITS / FEATURES

Does not Harden
Does not Kink
Soft Hand
Economically Priced
Buoyant
Easy to Splice

SPECIFICATIONS

Material : 100% HT Polypropylene Fiber
Type : T
Specific Gravity : 0,91 kg/dm³
Construction : 12 Strand Plaited
UV Resistance : Sufficient
Chemical Resistance : Very Good
Melting Point : 165°C
Critical Temperature : 80°C
Elongation at Break : Approx. %23
Fiber Water Absorption : None
Wet Abrasion : Sufficient
Dry Abrasion : Sufficient
Standard : EN ISO 1346
Length : 100-200 m Wooden Spool or Coil

Other Colours on Request

DIA (mm)	Weight (kg/100m)	Min. B.Load (kgf)	DIA (inch)	Weight (lbs/100ft)	Min. B.Load (lbs)
18	16,70	6.000	3/4"	11,22	13.200
20	18,10	6.500	13/16"	12,16	14.300
22	21,90	7.740	7/8"	14,72	17.028
24	26,00	9.060	1"	17,47	19.932
26	30,80	10.500	1-1/16"	20,70	23.100
28	35,40	12.900	1-1/8"	23,79	28.380
30	40,70	14.600	1-1/4"	27,35	32.120
32	46,30	16.400	1-5/16"	31,11	36.080
34	52,40	18.250	1-3/8"	35,21	40.150
36	58,60	20.100	1-1/2"	39,38	44.220
38	65,40	22.200	1-9/16"	43,95	48.840
40	72,30	24.300	1-5/8"	48,59	53.460
42	79,90	26.650	1-11/16"	53,69	58.630
44	87,50	29.000	1-3/4"	58,80	63.800
46	95,70	31.350	1-13/16"	64,31	68.970
48	104,00	33.700	2"	69,89	74.140
52	122,20	39.150	2-1/8"	82,12	86.130
56	142,00	44.600	2-1/4"	95,42	98.120
60	163,00	50.700	2-1/2"	109,54	111.540
64	185,00	56.800	2-5/8"	124,32	124.960
72	234,00	70.200	3"	157,25	154.440
80	289,00	86.000	3-1/4"	194,21	189.200
88	350,00	102.000	3-5/8"	235,20	224.400
96	417,00	120.000	4"	280,22	264.000

*Unspliced Break Load (All tests are in Accordance with ISO 2307)

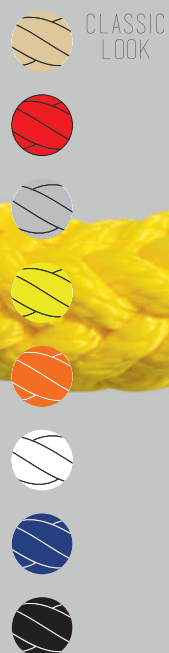





LUPES® SQUARE ▶ MOORING LINES

LUPES® SQUARE

APPLICATIONS

- Dock Line
- Anchor Line
- Towing Line

See Page 74

BENEFITS / FEATURES

- Does not Harden
- Does not Kink
- Soft Hand
- Durable
- High Breaking Load
- Easy to Splice
- Excellent Abrasion Resistance

SPECIFICATIONS

Material	:	100% HT Polyester Fiber
Type	:	L
Specific Gravity	:	1,38 kg/dm ³
Construction	:	8 Strand Plaited (4x2)
UV Resistance	:	Excellent
Chemical Resistance	:	Good
Melting Point	:	256°C
Critical Temperature	:	170°C
Elongation at Break	:	Approx. %15-20
Fiber Water Absorption	:	Approx. %1-2
Wet Abrasion	:	Good
Dry Abrasion	:	Good
Standard	:	EN ISO 1141
Length	:	100-200 m Wooden Spool or Coil

Other Colours on Request

DIA (mm)	Weight (kg/100m)	Min. B.Load (kgf)	DIA (inch)	Weight (lbs/100ft)	Min. B.Load (lbs)
12	10,90	2.875	1/2"	7,32	6.325
14	14,90	3.875	9/16"	10,01	8.525
16	19,40	5.000	5/8"	13,04	11.000
18	24,60	6.250	3/4"	16,53	13.750
20	30,40	8.250	13/16"	20,43	18.150
22	36,70	10.000	7/8"	24,66	22.000
24	43,70	11.500	1"	29,37	25.300
26	51,20	13.500	1-1/16"	34,41	29.700
28	59,50	15.500	1-1/8"	39,98	34.100
30	68,30	17.500	1-1/4"	45,90	38.500
32	77,70	20.000	1-5/16"	52,21	44.000
34	88,00	22.500	1-3/8"	59,14	49.500
36	98,40	25.000	1-1/2"	66,12	55.000
38	109,70	29.000	1-9/16"	73,72	63.800
40	121,00	33.000	1-5/8"	81,31	72.600
44	147,00	39.750	1-3/4"	98,78	87.450
48	175,00	46.500	2"	117,60	102.300
52	205,00	53.800	2-1/8"	137,76	118.360
56	238,00	61.700	2-1/4"	159,94	135.740

*Unspliced Break Load (All tests are in Accordance with ISO 2307)

CLASSIC LOOK



LUPA[®] SQUARE

APPLICATIONS

Dock Line
Anchor Line
Towing Line

See Page 74

BENEFITS / FEATURES

Does not Harden
Does not Kink
Soft Hand
Durable
High Breaking Load
Easy to Splice
Excellent Shock Absorption

SPECIFICATIONS

Material	: 100% HT Polyamide Fiber
Type	: L
Specific Gravity	: 1,14 kg/dm ³
Construction	: 8 Strand Plaited (4x2)
UV Resistance	: Very Good
Chemical Resistance	: Good
Melting Point	: 218°C
Critical Temperature	: 130°C
Elongation at Break	: Approx. %30-35
Fiber Water Absorption	: Approx. %3-4
Wet Abrasion	: Sufficient
Dry Abrasion	: Good
Standard	: EN ISO 1140
Length	: 100-200 m Plastic/Wooden Spool or Coil

Other Colours on Request

DIA (mm)	Weight (kg/100m)	Min. B.Load (kgf)	DIA (inch)	Weight (lbs/100ft)	Min. B.Load (lbs)
12	9,00	3.060	1/2"	6,05	6.732
14	12,30	4.250	9/16"	8,27	9.350
16	16,00	5.400	5/8"	10,75	11.880
18	20,50	6.875	3/4"	13,78	15.125
20	25,00	8.500	13/16"	16,80	18.700
22	30,50	10.250	7/8"	20,50	22.550
24	36,00	12.000	1"	24,19	26.400
26	42,50	14.500	1-1/16"	28,56	31.900
28	49,00	17.000	1-1/8"	32,93	37.400
30	56,00	19.000	1-1/4"	37,63	41.800
32	64,00	21.125	1-5/16"	43,01	46.475
34	72,50	24.310	1-3/8"	48,72	53.482
36	81,00	27.500	1-1/2"	54,43	60.500
38	90,50	30.750	1-9/16"	60,82	67.650
40	100,00	34.000	1-5/8"	67,20	74.800
44	121,00	40.800	1-3/4"	81,31	89.760
48	144,00	47.800	2"	96,77	105.160
52	170,00	55.600	2-1/8"	114,24	122.320
56	197,00	63.600	2-1/4"	132,38	139.920

* Unspliced Break Load (All tests are in Accordance with ISO 2307)



LUPA[®] SQUARE ▲ MOORING LINES





LUPP® SQUARE ▶ MOORING LINES

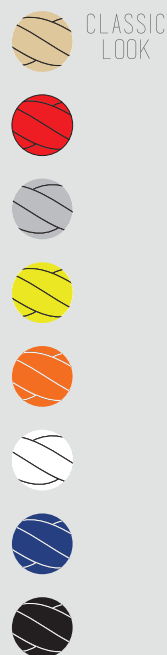

LUPP® SQUARE

APPLICATIONS

Dock Line
Towing Line
See Page 74

BENEFITS / FEATURES

Does not Harden
Does not Kink
Soft Hand
Economically Priced
Buoyant
Easy to Splice

SPECIFICATIONS

Material	: 100% HT Polypropylene Fiber
Type	: L
Specific Gravity	: 0,91 kg/dm ³
Construction	: 8 Strand Plaited (4x2)
UV Resistance	: Sufficient
Chemical Resistance	: Very Good
Melting Point	: 165°C
Critical Temperature	: 80°C
Elongation at Break	: Approx. %23
Fiber Water Absorption	: None
Wet Abrasion	: Sufficient
Dry Abrasion	: Sufficient
Standard	: EN ISO 1346
Length	: 100-200 m Plastic/Wooden Spool or Coil

Other Colours on Request

DIA (mm)	Weight (kg/100m)	Min. B.Load (kgf)	DIA (inch)	Weight (lbs/100ft)	Min. B.Load (lbs)
12	6,51	2.280	1/2"	4,37	5.016
14	8,86	3.225	9/16"	5,95	7.095
16	11,60	4.310	5/8"	7,80	9.482
18	14,60	5.350	3/4"	9,81	11.770
20	18,10	6.500	13/16"	12,16	14.300
22	21,90	7.740	7/8"	14,72	17.028
24	26,00	9.060	1"	17,47	19.932
26	30,80	10.500	1-1/16"	20,70	23.100
28	35,40	12.900	1-1/8"	23,79	28.380
30	40,70	14.600	1-1/4"	27,35	32.120
32	46,30	16.400	1-5/16"	31,11	36.080
34	52,40	18.250	1-3/8"	35,21	40.150
36	58,60	20.100	1-1/2"	39,38	44.220
38	65,40	22.200	1-9/16"	43,95	48.840
40	72,30	24.300	1-5/8"	48,59	53.460
44	87,50	29.150	1-3/4"	58,80	64.130
48	104,00	34.100	2"	69,89	75.020
52	122,00	39.400	2-1/8"	81,98	86.680
56	142,00	45.300	2-1/4"	95,42	99.660

*Unspliced Break Load (All tests are in Accordance with ISO 2307)

LUPA[®] SQUARE WINDLASS

APPLICATIONS

Dock Line
Anchor Line
Towing Line

See Page 74

BENEFITS / FEATURES

Does not Harden
Does not Kink
Extra Soft Hand
Durable
High Breaking Load
Easy to Splice
Excellent Shock Absorption

SPECIFICATIONS

Material	: 100% HT Polyamide Fiber
Type	: L
Specific Gravity	: 1,14 kg/dm ³
Construction	: 8 Strand Plaited (4x2)
UV Resistance	: Very Good
Chemical Resistance	: Good
Melting Point	: 218°C
Critical Temperature	: 130°C
Elongation at Break	: Approx. %30-35
Fiber Water Absorption	: Approx. %3-4
Wet Abrasion	: Sufficient
Dry Abrasion	: Good
Standard	: EN ISO 1140
Length	: 100-200 m Plastic/Wooden Spool or Coil

Other Colours on Request

DIA (mm)	Weight (kg/100m)	Min. B.Load (kgf)	DIA (inch)	Weight (lbs/100ft)	Min. B.Load (lbs)
13	8,80	3.400	1/2"	5,92	7.480
16	13,80	4.950	5/8"	9,28	10.890
19	20,80	6.930	3/4"	13,98	15.245
22	28,30	9.000	7/8"	19,02	19.800

*Unspliced Break Load (All tests are in Accordance with ISO 2307)



LUPA[®] SQUARE WINDLASS ▲ MOORING LINES





LUPES® TWIST ▶ MOORING LINES



CLASSIC LOOK

LUPES® TWIST

APPLICATIONS

- Dock Line
- Anchor Line
- Towing Line

See Page 74

BENEFITS / FEATURES

- Does not Harden
- Soft Hand
- Durable
- High Breaking Load
- Easy to Splice
- Excellent Abrasion Resistance

SPECIFICATIONS

Material	: 100% HT Polyester Fiber
Type	: A
Specific Gravity	: 1,38 kg/dm ³
Construction	: 3 Strand Plaited
UV Resistance	: Excellent
Chemical Resistance	: Good
Melting Point	: 256°C
Critical Temperature	: 170°C
Elongation at Break	: Approx. %15-20
Fiber Water Absorption	: Approx. %1-2
Wet Abrasion	: Good
Dry Abrasion	: Good
Standard	: EN ISO 1141
Length	: 100-200 m Plastic/Wooden Spool or Coil

Other Colours on Request

DIA (mm)	Weight (kg/100m)	Min. B.Load (kgf)	DIA (inch)	Weight (lbs/100ft)	Min. B.Load (lbs)
4	1,21	325	5/32"	0,81	715
5	1,90	515	3/16"	1,28	1.133
6	2,73	720	1/4"	1,83	1.584
8	4,85	1.300	5/16"	3,26	2.860
10	7,58	2.060	3/8"	5,09	4.532
12	10,90	2.875	1/2"	7,32	6.325
14	14,90	3.875	9/16"	10,01	8.525
16	19,40	5.000	5/8"	13,04	11.000
18	24,60	6.250	3/4"	16,53	13.750
20	30,30	8.250	13/16"	20,36	18.150
22	36,70	10.000	7/8"	24,66	22.000
24	43,70	11.500	1"	29,37	25.300
26	51,20	13.500	1-1/16"	34,41	29.700
28	59,40	15.500	1-1/8"	39,92	34.100
30	68,20	17.750	1-1/4"	45,83	39.050
32	77,60	20.000	1-5/16"	52,15	44.000
36	98,40	25.000	1-1/2"	66,12	55.000
40	121,00	33.000	1-5/8"	81,31	72.600
48	175,00	46.000	2"	117,60	101.200
56	238,00	62.000	2-1/4"	159,94	136.400
64	311,00	80.000	2-5/8"	208,99	176.000

*Unspliced Break Load (All tests are in Accordance with ISO 2307)

LUPA® TWIST

APPLICATIONS

Dock Line
Towing Line
Anchor Line

See Page 74

BENEFITS / FEATURES

Does not Harden
Soft Hand
Durable
High Breaking Load
Excellent Shock Absorption
Easy to Splice

SPECIFICATIONS

Material	: 100% HT Polyamide Fiber
Type	: A
Specific Gravity	: 1,14 kg/dm ³
Construction	: 3 Strand Plaited
UV Resistance	: Very Good
Chemical Resistance	: Good
Melting Point	: 218°C
Critical Temperature	: 130°C
Elongation at Break	: Approx. %30-35
Fiber Water Absorption	: Approx. %3-4
Wet Abrasion	: Sufficient
Dry Abrasion	: Good
Standard	: EN ISO 1140
Length	: 100-200 m Plastic/Wooden Spool or Coil

Other Colours on Request

DIA (mm)	Weight (kg/100m)	Min. B.Load (kgf)	DIA (inch)	Weight (lbs/100ft)	Min. B.Load (lbs)
4	0,98	380	5/32"	0,66	836
5	1,54	570	3/16"	1,03	1.254
6	2,22	810	1/4"	1,49	1.782
8	3,95	1.420	5/16"	2,65	3.124
10	6,17	2.160	3/8"	4,15	4.752
12	8,88	3.060	1/2"	5,97	6.732
14	12,10	4.250	9/16"	8,13	9.350
16	15,80	5.280	5/8"	10,62	11.616
18	20,00	6.875	3/4"	13,44	15.125
20	24,70	8.500	13/16"	16,60	18.700
22	29,90	10.250	7/8"	20,09	22.550
24	35,50	12.000	1"	23,86	26.400
26	41,70	14.500	1-1/16"	28,02	31.900
28	48,40	17.000	1-1/8"	32,52	37.400
30	55,50	19.000	1-1/4"	37,30	41.800
32	63,20	21.125	1-5/16"	42,47	46.475
36	80,00	27.500	1-1/2"	53,76	60.500
40	98,70	34.000	1-5/8"	66,33	74.800
48	142,00	48.000	2"	95,42	105.600
56	193,00	68.000	2-1/4"	129,70	149.600
64	253,00	84.500	2-5/8"	170,02	185.900

*Unspliced Break Load (All tests are in Accordance with ISO 2307)

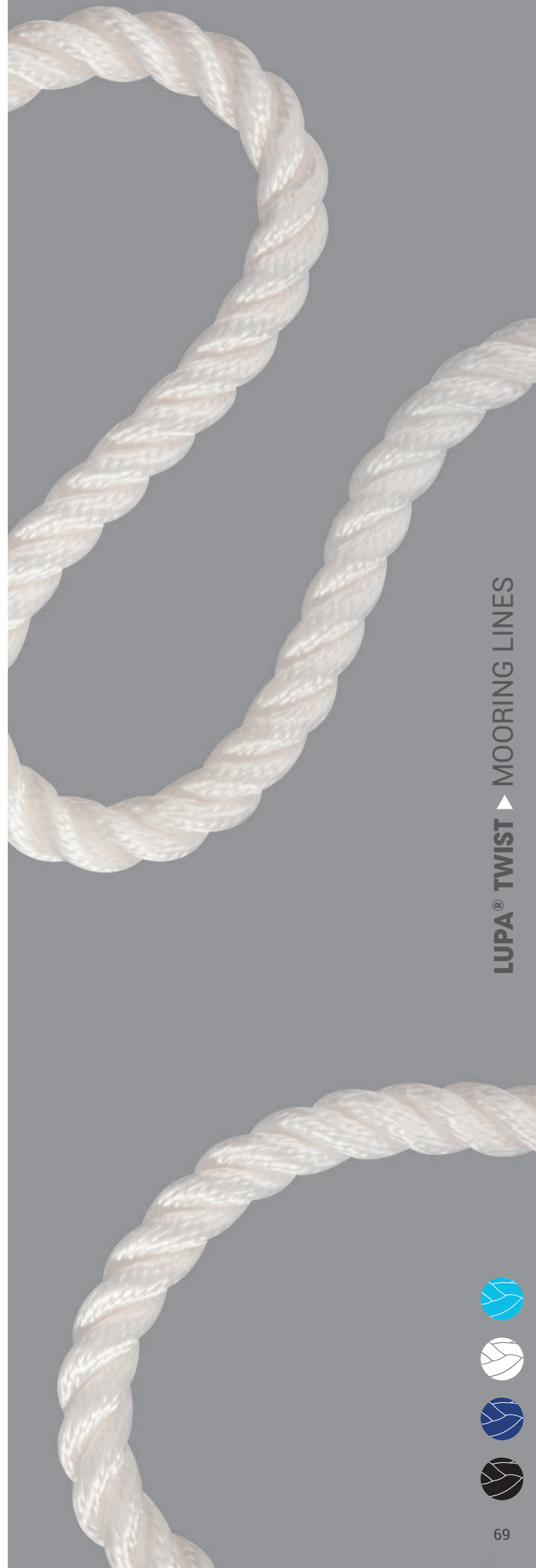

LUPA® TWIST ▲ MOORING LINES





LUPP® TWIST

APPLICATIONS

Dock Line
Towing Line
See Page 74

BENEFITS / FEATURES

Does not Harden
Soft Hand
Economically Priced
Buoyant
Easy to Splice

SPECIFICATIONS

Material : 100% HT Polypropylene Fiber
Type : A
Specific Gravity : 0,91 kg/dm³
Construction : 3 Strand Plaited
UV Resistance : Sufficient
Chemical Resistance : Very Good
Melting Point : 165°C
Critical Temperature : 80°C
Elongation at Break : Approx. %23
Fiber Water Absorption : None
Wet Abrasion : Sufficient
Dry Abrasion : Sufficient
Standard : EN ISO 1346
Length : 100-200 m Plastic/Wooden Spool or Coil

Other Colours on Request

DIA (mm)	Weight (kg/100m)	Min. B.Load (kgf)	DIA (inch)	Weight (lbs/100ft)	Min. B.Load (lbs)
4	0,72	320	5/32"	0,48	704
5	1,13	480	3/16"	0,76	1.056
6	1,63	680	1/4"	1,10	1.496
8	2,89	1.200	5/16"	1,94	2.640
10	4,52	1.730	3/8"	3,04	3.806
12	6,51	2.550	1/2"	4,37	5.610
14	8,86	3.410	9/16"	5,95	7.502
16	11,60	4.330	5/8"	7,80	9.526
18	14,60	5.400	3/4"	9,81	11.880
20	18,10	6.500	13/16"	12,16	14.300
22	21,90	7.740	7/8"	14,72	17.028
24	26,00	9.180	1"	17,47	20.196
26	30,60	10.810	1-1/16"	20,56	23.782
28	35,40	12.900	1-1/8"	23,79	28.380
30	40,70	14.600	1-1/4"	27,35	32.120
32	46,30	16.400	1-5/16"	31,11	36.080
36	58,60	20.100	1-1/2"	39,38	44.220
40	72,30	24.300	1-5/8"	48,59	53.460
48	104,00	34.170	2"	69,89	75.174
56	142,00	44.600	2-1/4"	95,42	98.120
64	185,00	57.120	2-5/8"	124,32	125.664

*Unspliced Break Load (All tests are in Accordance with ISO 2307)





CLASSIC
LOOK

LUPES® TWIST SOFT

APPLICATIONS

Dock Line
See Page 74

BENEFITS / FEATURES

Soft Hand
Easy to Splice
Classic Look

SPECIFICATIONS

Material	: Polyester Staple Fiber
Specific Gravity	: 1,38 kg/dm ³
Construction	: 3 Strand Plaited
UV Resistance	: Good
Chemical Resistance	: Good
Melting Point	: 225°C
Critical Temperature	: 170°C
Elongation at Break	: Approx. %15-20
Wet Abrasion	: Sufficient
Dry Abrasion	: Sufficient
Standard	: -
Length	: 100-200 m Plastic/Wooden Spool or Coil

Other Colours & Large Diameters Upon Request

DIA (mm)	Weight (kg/100m)	Min. B.Load (kgf)	DIA (inch)	Weight (lbs/100ft)	Min. B.Load (lbs)
8	5,05	850	5/16"	3,39	1.870
10	7,55	1.200	3/8"	5,07	2.640
12	10,10	1.600	1/2"	6,79	3.520
14	15,10	2.400	9/16"	10,15	5.280
16	18,90	3.400	5/8"	12,70	7.480
18	21,40	4.700	3/4"	14,38	10.340
20	30,25	5.500	13/16"	20,33	12.100

*Unspliced Break Load (All tests are in Accordance with ISO 2307)

LUPES® SAFETY NET

APPLICATIONS

Guard Rail Netting
See Page 74

BENEFITS / FEATURES

Mesh Width Approx. 45 mm
Width of Net 60 cm (2 mm-2,5 mm)
Width of Net 80 cm (3 mm)

SPECIFICATIONS

Material	: HT Polyester Fiber
Specific Gravity	: 1,38 kg/dm ³
Construction	: 12-16 Plaited
UV Resistance	: Excellent
Chemical Resistance	: Good
Melting Point	: 256°C
Critical Temperature	: 170°C
Elongation at Break	: Approx. %1-2
Wet Abrasion	: Good
Dry Abrasion	: Good
Standard	: -
Length	: 100-200 m Plastic Spool

Other Colours on Request

DIA (mm)	Weight (kg/100m)	Min. B.Load (kgf)	DIA (inch)	Weight (lbs/100ft)	Min. B.Load (lbs)
2	0,32		5/64"	0,22	
2,5	0,50		7/64"	0,34	
3	0,72		1/8"	0,48	

*Unspliced Break Load (All tests are in Accordance with ISO 2307)



LUPES® COVER

APPLICATIONS

Fender Mooring

See Page 74

BENEFITS / FEATURES

Good Knot Retention
Supple Surface
Great for Fenders
Easy Handling

SPECIFICATIONS

Material	: 100% HT Polyester Fiber
Specific Gravity	: 1,38 kg/dm ³
Construction	: 16-24-32 Plaited
UV Resistance	: Excellent
Chemical Resistance	: Good
Melting Point	: 256°C
Critical Temperature	: 170°C
Working Stretch	: <13%
Wet Abrasion	: Good
Dry Abrasion	: Good
Standard	: -
Length	: 100-200 m Plastic Spool

Other Colours & Upon Request

LUPA® COVER

APPLICATIONS

Fender Mooring

See Page 74

BENEFITS / FEATURES

Good Knot Retention
Supple Surface
Great for Fenders
Easy Handling

SPECIFICATIONS

Material	: 100% Polyamide Fiber
Specific Gravity	: 1,14 kg/dm ³
Construction	: 16-24-32 Plaited
UV Resistance	: Very Good
Chemical Resistance	: Good
Melting Point	: 218°C
Critical Temperature	: 130°C
Working Stretch	: <20%
Wet Abrasion	: Sufficient
Dry Abrasion	: Good
Standard	: -
Length	: 100-200 m Plastic Spool

Other Colours on Request

DIA (mm)	Weight (kg/100m)	B. Load (kgf)	DIA (inch)	Weight (lbs/100ft)	B. Load (lbs)
4-6			5/32"- 1/4"		
5-7			3/16"- 9/32"		
6-8			1/4"- 5/16"		
7-10			5/32"- 3/8"		
8-12			5/16"- 1/2"		
10-14			3/8"- 9/16"		
12-16			1/2"- 5/8"		
14-18			9/16"- 3/4"		
16-20			5/8"- 13/16"		
18-22			3/4"- 7/8"		
20-24			13/16"- 1"		

*Unspliced Break Load (All tests are in Accordance with ISO 2307)

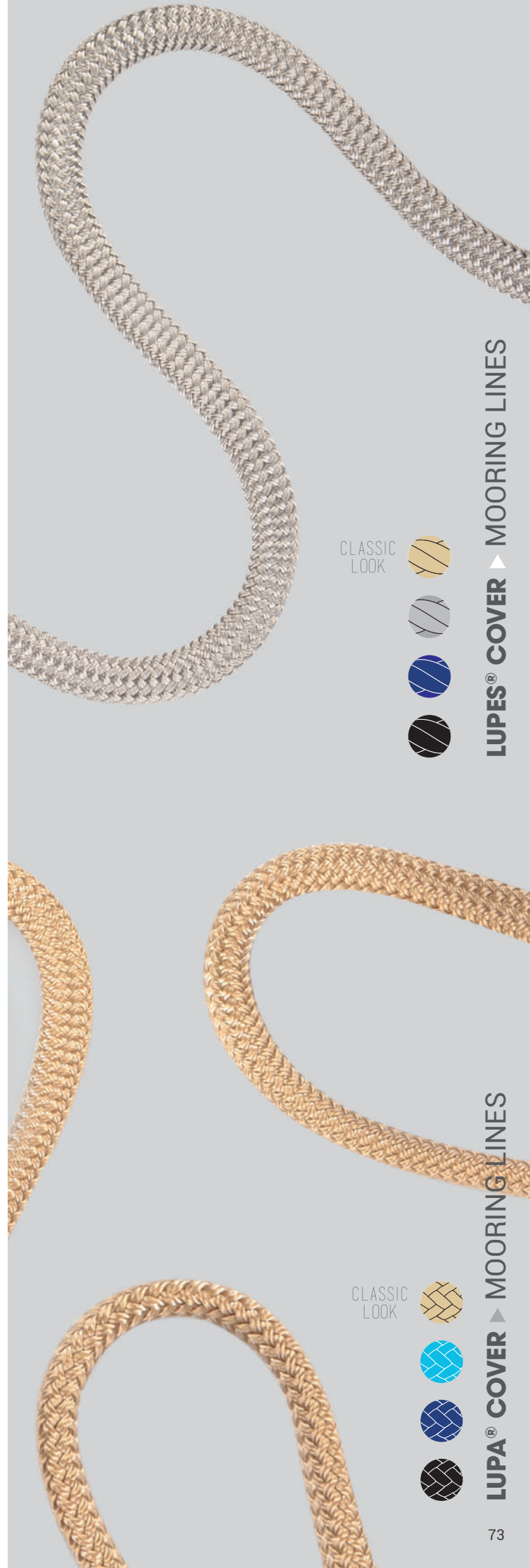

CLASSIC LOOK



LUPES® COVER ▲ MOORING LINES

CLASSIC LOOK



LUPA® COVER ▲ MOORING LINES

ROPE APPLICATIONS FOR MOORING LINES

ROPE NAMES	LUPES® VIPERA / PREMIER	LUPA® VIPERA / PREMIER / USA	LUPP® VIPERA / PREMIER	LUPES® EUROPA	LUPA® EUROPA	LUPES® ROUND	LUPA® ROUND	LUPP® ROUND	LUPES® SQUARE	LUPA® SQUARE / WINDLASS	LUPP® SQUARE	LUPES® TWIST	LUPA® TWIST	LUPP® TWIST	LUPES® TWIST SOFT	DYNE VIPERA® COATED / UNCOATED
APPLICATIONS																
PAGE	49/54	50/55/57	51/56	58	59	60	61	62	64	65/67	66	68	69	70	72	52/53
DOCK LINE																
RACING	✓			✓		✓	✓		✓	✓		✓	✓			
CRUISING	✓			✓		✓	✓		✓	✓		✓	✓			
DINGHY	✓			✓								✓	✓			
MOTOR YACHT	✓	✓	✓	✓	✓	✓	✓	✓	✓	✓	✓	✓	✓	✓	✓	
SUPER YACHT	✓	✓		✓	✓	✓	✓	✓	✓	✓	✓					✓
TOWING LINE																
RACING						✓			✓			✓		✓		
CRUISING	✓			✓		✓			✓			✓		✓		
DINGHY														✓		
MOTOR YACHT	✓	✓	✓	✓	✓	✓	✓	✓	✓	✓	✓	✓	✓	✓		
SUPER YACHT	✓	✓		✓	✓	✓	✓	✓	✓	✓	✓					✓
ANCHOR LINE																
RACING	✓			✓		✓	✓		✓	✓		✓	✓			
CRUISING	✓			✓		✓	✓		✓	✓		✓	✓			
DINGHY	✓			✓								✓	✓			
MOTOR YACHT	✓	✓		✓	✓	✓	✓		✓	✓		✓	✓			
SUPER YACHT	✓	✓		✓	✓	✓	✓		✓	✓						

LUPES® VIPERA



MOORING METHODS & FORMULAS FOR CALCULATING CUSTOM DOCK LINES

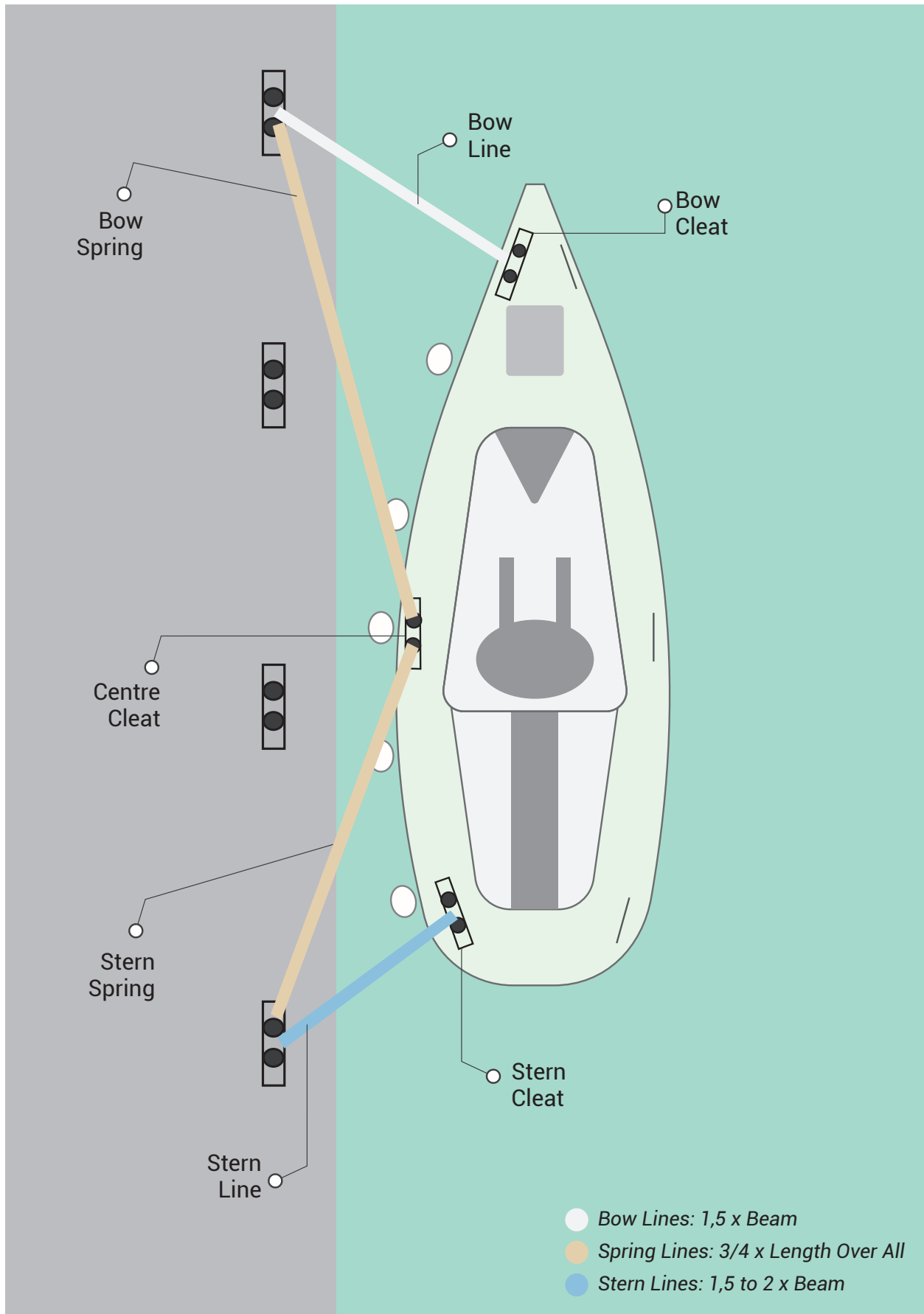

WATER SPORTS LINES



LUPES® WAX

APPLICATIONS

Parasailing Line

BENEFITS / FEATURES

Outstanding Flexibility
High Breaking Load
Easy to Splice



SPECIFICATIONS

Material	:	Cover: HT Waxed Polyester Fiber Core: HT Polyester Fiber
Specific Gravity	:	1,38 kg/dm ³
Construction	:	Cover: 16 Plaited Core: 16 Plaited
UV Resistance	:	Excellent
Chemical Resistance	:	Good
Melting Point	:	256°C
Critical Temperature	:	170°C
Working Stretch	:	<6%
Fiber Water Absorption	:	Approx. %1-2
Wet Abrasion	:	Excellent
Length	:	100-200 m Plastic Spool

Other Colours & Larger Diameters Upon Request

DIA (mm)	Weight (kg/100m)	B.Load (kgf)	DIA (inch)	Weight (lbs/100ft)	B.Load (lbs)
9	7,50	1.820	11/32"	5,04	4.004
10	9,05	2.330	3/8"	6,08	5.126
11	10,70	2.630	7/16"	7,19	5.786
12	12,70	3.270	1/2"	8,53	7.194

*Unspliced Break Load (All Tests are in Accordance with ISO 2307)



LUPES® WAX ► WATER SPORTS LINES



DYNE K®

APPLICATIONS

Parasailing Line

BENEFITS / FEATURES

- Superior Abrasion Resistance
- Excellent Breaking Load (SK99)
- Buoyant
- Durable
- Very Low Stretch
- Lightweight
- Easy to Splice
- Does not Kink



SPECIFICATIONS

Material	: Coated Dyneema® SK 78/99 Fiber
Specific Gravity	: 0,97 kg/dm ³
Construction	: 12 Strand Braided
UV Resistance	: Excellent
Chemical Resistance	: Excellent
Melting Point	: 147°C
Critical Temperature	: 65°C
Working Stretch	: <1%
Fiber Water Absorption	: None
Wet Abrasion	: Excellent
Dry Abrasion	: Excellent
Length	: 100-200 m Plastic Spool

Other Colours & Larger Diameters Upon Request

DIA (mm)	Weight (kg/100m)	B.Load (kgf) SK78	B.Load (kgf) SK99	DIA (inch)	Weight (lbs/100ft)	B.Load (lbs) SK78	B.Load (lbs) SK99
6	2,30	4.080	4.810	1/4"	1,55	8.976	10.582
8	4,00	7.040	8.310	5/16"	2,69	15.488	18.282
10	6,10	10.750	12.690	3/8"	4,10	23.650	27.918
12	8,70	15.300	18.050	1/2"	5,85	33.660	39.710

*Unspliced Break Load (All Tests are in Accordance with ISO 2307)



OVERPOWER

APPLICATIONS

Windsurf Outhauls
Windsurf Downhauls

BENEFITS / FEATURES

Excellent Durability
Low Stretch
High Strength



SPECIFICATIONS

Material	: Coated Dyneema® SK 78 Fiber
Specific Gravity	: 0,97 kg/dm ³
Construction	: 12 Strand Braided
UV Resistance	: Excellent
Chemical Resistance	: Excellent
Melting Point	: 147°C
Critical Temperature	: 65°C
Working Stretch	: <2%
Fiber Water Absorption	: None
Wet Abrasion	: Excellent
Dry Abrasion	: Excellent
Length	: 100-200 m Plastic Spool

Other Colours & Larger Diameters Upon Request

DIA (mm)	Weight (kg/100m)	B.Load (kgf)	DIA (inch)	Weight (lbs/100ft)	B.Load (lbs)
3,8	0,90	650	5/32"	0,60	1.430
4,5	1,20	750	11/64"	0,80	1.650

*Unspliced Break Load (All Tests are in Accordance with ISO 2307)

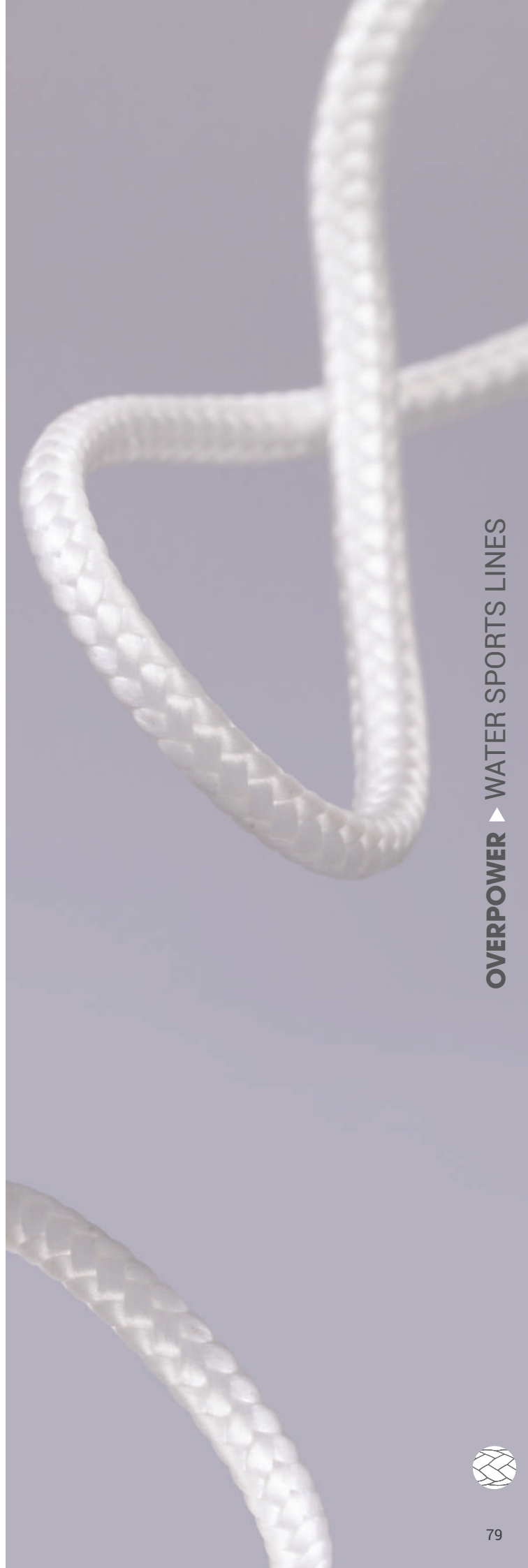

OVERPOWER ▲ WATER SPORTS LINES

SAILMAKER LINES

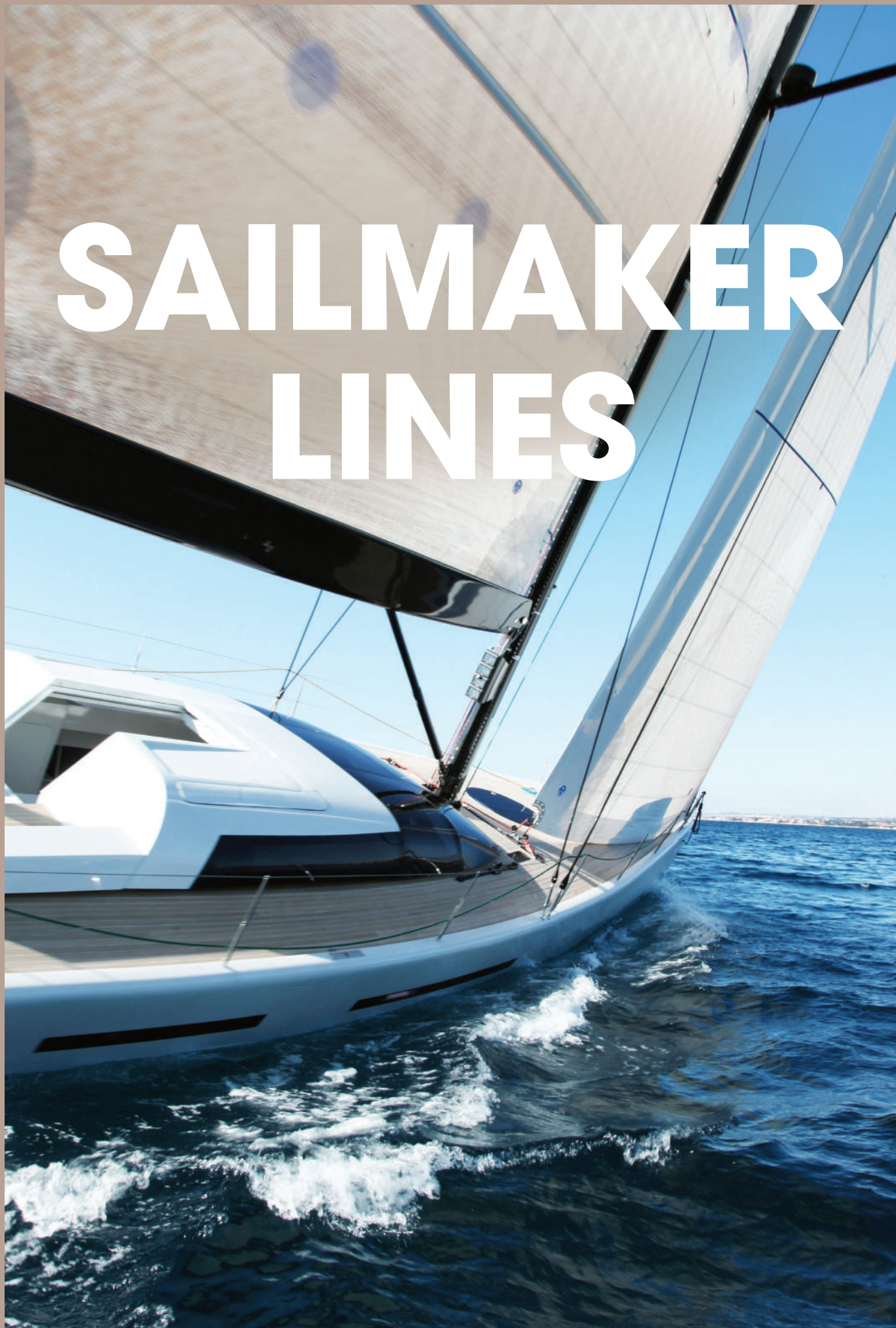

DINGHY ROCK V[®] MIX

APPLICATIONS

Main Halyard

BENEFITS / FEATURES

Good Performance in Jammers
High Breaking Load
Extremely Low Stretch
Easy to Splice

SPECIFICATIONS

Material	:	Cover: HT Polyester Fiber Core: Coated Vectran [®] Fiber
Specific Gravity	:	Approx. 1,38 kg/dm ³
Construction	:	Cover: 20-24 Plaited Core: 12 Plaited
UV Resistance	:	Poor
Chemical Resistance	:	Good
Melting Point	:	256°C
Critical Temperature	:	170°C
Working Stretch	:	<1%
Fiber Water Absorption	:	Approx. %1-2
Wet Abrasion	:	Good
Length	:	100-200 m Plastic Spool

Other Colours & Larger Diameters Upon Request

DIA (mm)	Weight (kg/100m)	B.Load (kgf)	DIA (inch)	Weight (lbs/100ft)	B.Load (lbs)
3	1,10	500	1/8"	0,74	1.100
4	1,30	750	5/32"	0,87	1.650
5	1,85	1.000	3/16"	1,24	2.200
6	2,85	1.500	1/4"	1,92	3.300
7	3,70	2.000	9/32"	2,49	4.400

*Unspliced Break Load (All Tests are in Accordance with ISO 2307)



DINGHY ROCK V[®] MIX ▲ SAILMAKER LINES

ROCK A[®] MIX

APPLICATIONS

Leech Line

BENEFITS / FEATURES

Good Performance in Jammers
High Breaking Load
Extremely Low Stretch
Easy to Splice

SPECIFICATIONS

Material	:	Cover: HT Polyester Fiber Core: Twaron [®] Fiber
Specific Gravity	:	Approx. 1,40 kg/dm ³
Construction	:	Cover: 20-24 Plaited Core: 12 Plaited
UV Resistance	:	Poor
Chemical Resistance	:	Good
Melting Point	:	256°C
Critical Temperature	:	170°C
Working Stretch	:	<1,5%
Fiber Water Absorption	:	Approx. %2-5
Wet Abrasion	:	Good
Length	:	100-200 m Plastic Spool

Other Colours & Larger Diameters Upon Request

DIA (mm)	Weight (kg/100m)	B.Load (kgf)	DIA (inch)	Weight (lbs/100ft)	B.Load (lbs)
3	0,90	500	1/8"	0,60	1.100
4	1,05	750	5/32"	0,71	1.650
5	1,50	1.000	3/16"	1,01	2.200
6	2,35	1.500	1/4"	1,58	3.300

*Unspliced Break Load (All Tests are in Accordance with ISO 2307)



ROCK A[®] MIX ▲ SAILMAKER LINES



LUPES® TOUGH

APPLICATIONS

Leech Line

BENEFITS / FEATURES

Very Small Lay Length
Highly Compact
Low Stretch
Smooth Sheathing
Excellent Stiffness & Roundness

SPECIFICATIONS

Material	:	Cover: HT Polyester Fiber Core: HT Polyester Fiber
Specific Gravity	:	1,38 kg/dm ³
Construction	:	Cover: 16 Plaited Core: Parallel Braided
UV Resistance	:	Excellent
Chemical Resistance	:	Good
Melting Point	:	256°C
Critical Temperature	:	170°C
Working Stretch	:	<5%
Fiber Water Absorption	:	Approx. %1-2
Wet Abrasion	:	Good
Length	:	100-200 m Plastic Spool

Other Colours & Larger Diameters Upon Request

DIA (mm)	Weight (kg/100m)	B.Load (kgf)	DIA (inch)	Weight (lbs/100ft)	B.Load (lbs)
3	1,00	250	1/8"	0,67	550
4	1,45	375	5/32"	0,97	825
5	1,95	500	3/16"	1,31	1.100
6	2,85	725	1/4"	1,92	1.595
7	3,90	1.000	9/32"	2,62	2.200
8	5,40	1.250	5/16"	3,63	2.750

*Unspliced Break Load (All Tests are in Accordance with ISO 2307)



LUPES® TWIST

APPLICATIONS

Leech Line

BENEFITS / FEATURES

Does not Harden
Soft Hand
Durable
High Breaking Load
Easy to Splice

SPECIFICATIONS

Material	:	100% HT Polyester Fiber
Specific Gravity	:	1,38 kg/dm ³
Construction	:	3 Strand Plaited
UV Resistance	:	Excellent
Chemical Resistance	:	Good
Melting Point	:	256°C
Critical Temperature	:	170°C
Elongation at Break	:	Approx. %15-20
Fiber Water Absorption	:	Approx. %1-2
Wet Abrasion	:	Good
Standard	:	EN ISO 1141
Length	:	100-200 m Plastic Spool

Other Colours & Larger Diameters Upon Request

DIA (mm)	Weight (kg/100m)	Min. B.Load (kgf) Unspliced	DIA (inch)	Weight (lbs/100ft)	Min. B.Load (lbs) Unspliced
4	1,21	325	5/32"	0,81	715
5	1,90	515	3/16"	1,28	1.133
6	2,73	720	1/4"	1,83	1.584
8	4,85	1.300	5/16"	3,26	2.860
10	7,58	2.060	3/8"	5,09	4.532

*Unspliced Break Load (All Tests are in Accordance with ISO 2307)

ARAMID K



APPLICATIONS

Leech Line

BENEFITS / FEATURES

No Creep Under Constant Loads
Excellent Heat Resistance
Extremely Low Stretch

SPECIFICATIONS

Material	:	100% Twaron® Fiber
Specific Gravity	:	Approx. 1,44 kg/dm ³
Construction	:	8 Plaited (Hollow Braid)
UV Resistance	:	Poor
Chemical Resistance	:	Excellent
Melting Point	:	500°C
Critical Temperature	:	350°C
Working Stretch	:	<1,5%
Fiber Water Absorption	:	Approx. %2-5
Wet Abrasion	:	Excellent
Wet Abrasion	:	Excellent
Length	:	100-200 m Plastic Spool

Other Colours & Larger Diameters Upon Request

DIA (mm)	Weight (kg/100m)	B.Load (kgf)	DIA (inch)	Weight (lbs/100ft)	B.Load (lbs)
3	0,55	475	1/8"	0,37	1.045
4	1,10	850	5/32"	0,74	1.870
5	1,60	1.200	3/16"	1,08	2.640
6	2,15	1.600	1/4"	1,44	3.520

*Unspliced Break Load (All Tests are in Accordance with ISO 2307)

VECT K®

APPLICATIONS

Leech Line

BENEFITS / FEATURES

No Creep Under Constant Loads
High Breaking Load
Extremely Low Stretch
Perfect for Static Applications
Easy to Splice

SPECIFICATIONS

Material	:	Coated Vectran® Fiber
Specific Gravity	:	1,40 kg/dm ³
Construction	:	12 Strand Plaited
UV Resistance	:	Poor
Chemical Resistance	:	Excellent
Melting Point	:	300°C
Critical Temperature	:	200°C
Working Stretch	:	<1%
Fiber Water Absorption	:	Approx. %1
Wet Abrasion	:	Excellent
Dry Abrasion	:	Excellent
Length	:	100-200 m Plastic Spool

Other Colours & Larger Diameters Upon Request

DIA (mm)	Weight (kg/100m)	B.Load (kgf)	DIA (inch)	Weight (lbs/100ft)	B.Load (lbs)
3	0,60	720	1/8"	0,40	1.584
4	1,20	1.430	5/32"	0,81	3.146
5	2,10	2.500	3/16"	1,41	5.500
6	3,00	3.575	1/4"	2,02	7.865
8	5,40	6.450	5/16"	3,63	14.190

*Unspliced Break Load (All Tests are in Accordance with ISO 2307)



ARAMID K ▲ SAILMAKER LINES



VECT K® ▲ SAILMAKER LINES



Vectran™



LUPES® SOLID

APPLICATIONS

Luff Line/Leech Line

BENEFITS / FEATURES

Easy Handling
Very Stable Round Cross-Section

SPECIFICATIONS

Material	: 100% HT Polyester Fiber
Specific Gravity	: 1,38 kg/dm ³
Construction	: Solid Braid (12 Plaited)
UV Resistance	: Excellent
Chemical Resistance	: Good
Melting Point	: 256°C
Critical Temperature	: 170°C
Working Stretch	: <6%
Fiber Water Absorption	: Approx. %1-2
Wet Abrasion	: Good
Dry Abrasion	: Good
Length	: 100-200 m Plastic Spool

Other Colours & Larger Diameters Upon Request

DIA (mm)	Weight (kg/100m)	B.Load (kgf)	DIA (inch)	Weight (lbs/100ft)	B.Load (lbs)
3	0,75	130	1/8"	0,50	286
4	1,15	220	5/32"	0,77	484
5	1,50	330	3/16"	1,01	726
6	2,25	450	1/4"	1,51	990
8	3,75	780	5/16"	2,52	1.716

*Unspliced Break Load (All Tests are in Accordance with ISO 2307)



ELASTIC CORD

APPLICATIONS

Leech Line

BENEFITS / FEATURES

Premium Quality Rubber Core
Durable
High Elongation
Compact Construction

SPECIFICATIONS

Material	: Cover: HT Polyester Fiber Core: Elastic Rubber
Specific Gravity	: Approx. 1,38 kg/dm ³
Construction	: Cover: 32 Plaited Core: Parallel Braid
UV Resistance	: Excellent
Chemical Resistance	: Good
Melting Point	: 256°C
Critical Temperature	: 170°C
Fiber Water Absorption	: Approx. %1-2
Wet Abrasion	: Good
Dry Abrasion	: Good
Length	: 100-200 m Plastic Spool

Other Colours & Larger Diameters Upon Request

DIA (mm)	Weight (kg/100m)	B.Load (kgf)	DIA (inch)	Weight (lbs/100ft)	B.Load (lbs)
3	0,75	-	1/8"	0,50	-
4	1,30	-	5/32"	0,87	-
5	2,10	-	3/16"	1,41	-
6	3,00	-	1/4"	2,02	-
8	4,30	-	5/16"	2,89	-
10	8,20	-	3/8"	5,51	-
12	12,00	-	1/2"	8,06	-

*Unspliced Break Load (All Tests are in Accordance with ISO 2307)

LUPES® CORD

APPLICATIONS

Luff Line / Leech Line

BENEFITS / FEATURES

Outstanding Flexibility
Cost-Efficient
Low Stretch

SPECIFICATIONS

Material	:	Cover: HT Polyester Fiber Core: HT Polyester Fiber
Specific Gravity	:	1,38 kg/dm ³
Construction	:	Cover: 16 Plaited Core: Parallel Braided
UV Resistance	:	Excellent
Chemical Resistance	:	Good
Melting Point	:	256°C
Critical Temperature	:	170°C
Working Stretch	:	<5%
Fiber Water Absorption	:	Approx. %1-2
Wet Abrasion	:	Good
Length	:	100-200 m Plastic Spool

Other Colours & Larger Diameters Upon Request

DIA (mm)	Weight (kg/100m)	B.Load (kgf)	DIA (inch)	Weight (lbs/100ft)	B.Load (lbs)
3	0,85	180	1/8"	0,57	396
4	1,20	300	5/32"	0,81	660
5	1,95	460	3/16"	1,31	1.012
6	2,70	660	1/4"	1,81	1.452

*Unspliced Break Load (All Tests are in Accordance with ISO 2307)

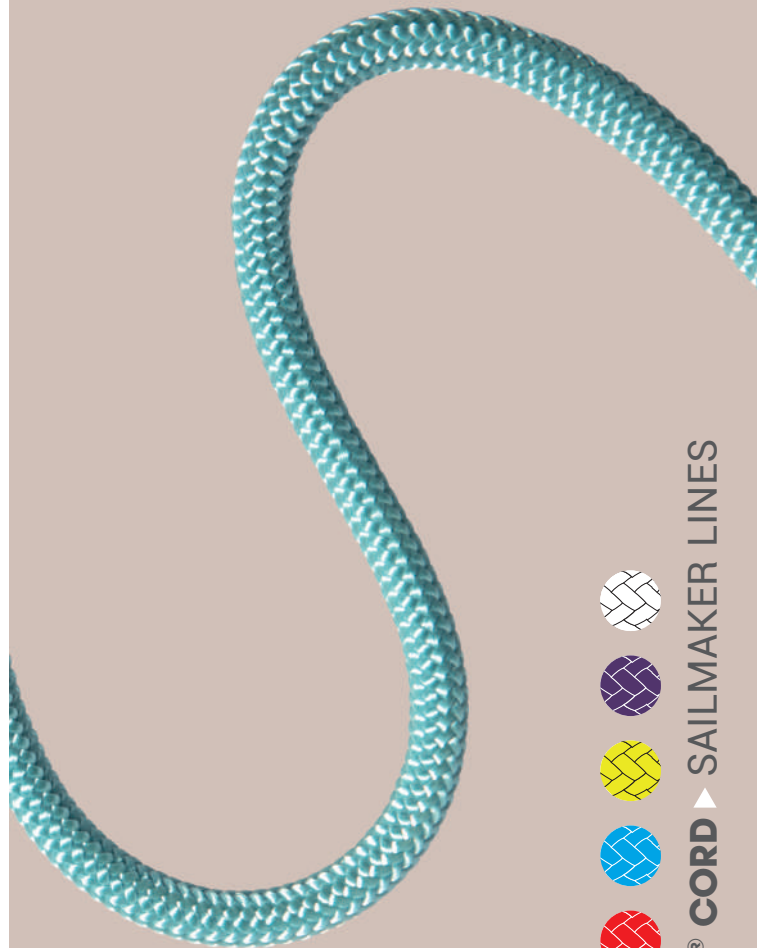

LUPES® CORD ▲ SAILMAKER LINES

LUPA® CORD

APPLICATIONS

Luff Line/Leech Line

BENEFITS / FEATURES

Outstanding Flexibility
Cost-Efficient
Excellent Shock Absorption

SPECIFICATIONS

Material	:	Cover: HT Polyamide Fiber Core: HT Polyamide Fiber
Specific Gravity	:	1,14 kg/dm ³
Construction	:	Cover: 16 Plaited Core: Parallel Braided
UV Resistance	:	Very Good
Chemical Resistance	:	Good
Melting Point	:	218°C
Critical Temperature	:	130°C
Working Stretch	:	<12%
Fiber Water Absorption	:	Approx. %3-4
Wet Abrasion	:	Sufficient
Length	:	100-200 m Plastic Spool

Other Colours & Larger Diameters Upon Request

DIA (mm)	Weight (kg/100m)	B.Load (kgf)	DIA (inch)	Weight (lbs/100ft)	B.Load (lbs)
3	0,70	200	1/8"	0,47	440
4	1,00	330	5/32"	0,67	726
5	1,60	500	3/16"	1,08	1.100
6	2,25	720	1/4"	1,51	1.584

*Unspliced Break Load (All Tests are in Accordance with ISO 2307)

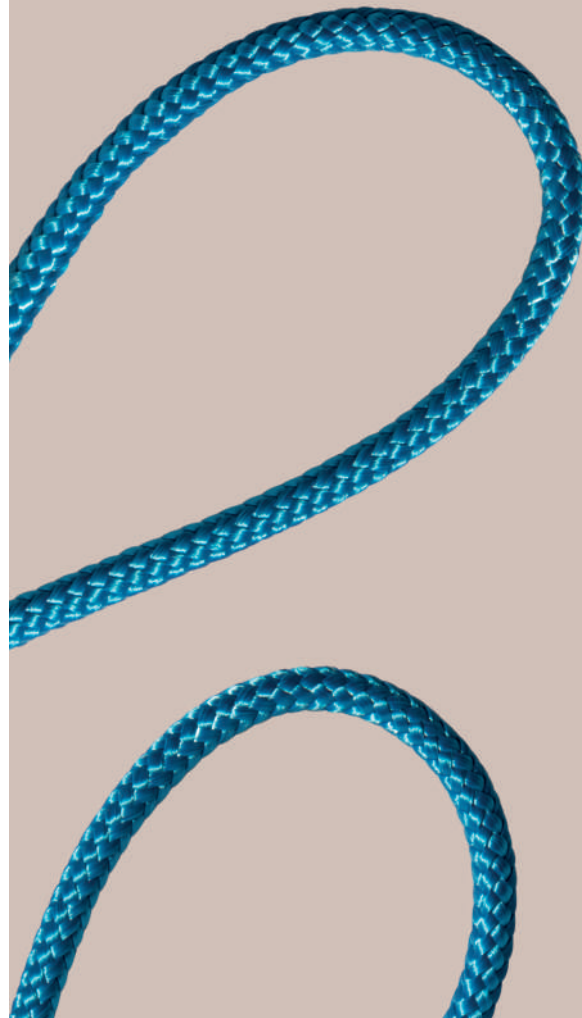

LUPA® CORD ▲ SAILMAKER LINES

LE-1 BAND WEBBING SLING

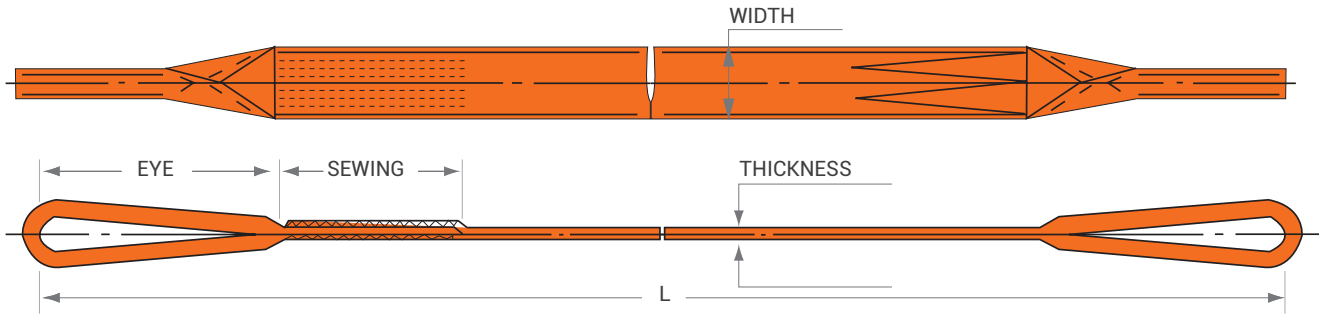

SPECIFICATIONS





Material : 100% HT Polyester Webbing
 Standard : EN 1492-1+A1
 Safety Factor : 7:1





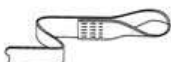

BENEFITS / FEATURES

High quality product with the 7:1 safety factor
 Produced from the high strength polyester webbing
 Various sizes available for every application
 Not slippery
 High resistance to chemical and oil contamination
 Custom made slings for specific applications may be made to customer specifications
 Various colour are available



	With (mm)	Working Load (kgf 100%)	Working Load (kgf 80%)	Working Load (kgf 200%)	Angle (0-45°) Working Load (kgf)	Angle (45-60°) Working Load (kgf)	Breaking Load (kgf)	Working Load (kgf)	Length (m)
VIOLET	30-50	1000	800	2000	1400	1000	7000	1000	1-10
GREEN	70	2000	1600	4000	2800	2000	14000	2000	2-10
YELLOW	90	3000	2400	6000	4200	3000	21000	3000	2-10
GRAY	120	4000	3200	8000	5600	4000	28000	4000	4-10
RED	150	5000	4000	10000	7000	5000	35000	5000	4-10
BROWN	180	6000	4800	12000	8400	6000	42000	6000	4-10
BLUE	250	8000	6400	16000	11200	8000	56000	8000	5-10
ORANGE	300	10000	8000	20000	14000	10000	70000	10000	5-10

-  1. Flat eye
-  2. Reversed eye
-  3. Folded eye 1/2 width from 1 side
-  4. Folded eye 1/2 width from 2 sides
-  5. Folded eye 1/3 width

	0° 100%		60° 85%
	30° 95%		90° 70%
	45° 90%		120° 50%

LE-2 ROUND WEBBING SLING

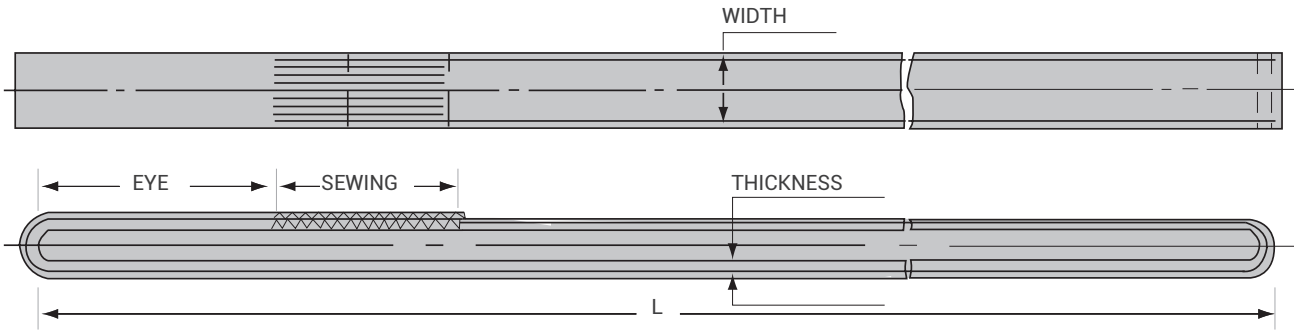

SPECIFICATIONS

Material : 100% HT Polyester Webbing
 Standard : EN 1492-2+A1
 Safety Factor : 7:1

BENEFITS / FEATURES

High quality product with the 7:1 safety factor
 Produced from the high strength polyester webbing
 Various sizes available for every application
 Not slippery
 High resistance to chemical and oil contamination
 Custom made slings for specific applications may be made to customer specifications
 Various colour are available

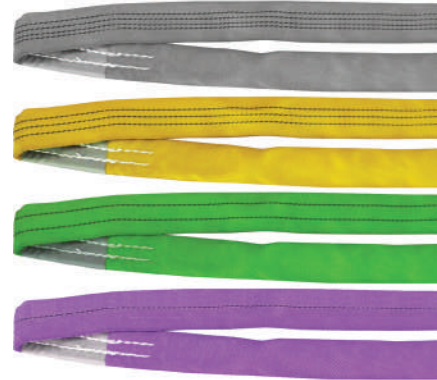

	With (mm)	Working Load (kgf 100%)	Working Load (kgf 80%)	Working Load (kgf 200%)	Angle (0-45°) Working Load (kgf)	Angle (45-60°) Working Load (kgf)	Breaking Load (kgf)	Working Load (kgf)	Length (m)
VIOLET	25	1000	800	2000	1400	1000	7000	1000	1-10
GREEN	50	2000	1600	4000	2800	2000	14000	2000	2-10
YELLOW	75	3000	2400	6000	4200	3000	21000	3000	2-10
GRAY	100	4000	3200	8000	5600	4000	28000	4000	4-10
RED	125	5000	4000	10000	7000	5000	35000	5000	4-10
BROWN	150	6000	4800	12000	8400	6000	42000	6000	4-10
BLUE	200	8000	6400	16000	11200	8000	56000	8000	5-10
ORANGE	250	10000	8000	20000	14000	10000	70000	10000	5-10

	0° 100%		60° 85%
	30° 95%		90° 70%
	45° 90%		120° 50%

ACCESSORIES



BC-46 P
BOSUN'S CHAIR (PROFESSIONAL)
 Material : Polyester
 Size : S/M, L/XL
 Weight Approx: 2084 g
 Webbing : Polyester 45 mm
 D-Rings : Ø 9 mm 304 Stainless Steel (EN 362)



BC-46 C
BOSUN'S CHAIR (COMFORT)
 Material : Polyester
 Size : S/M, L/XL
 Weight Approx: 1690 g
 Webbing : Polyester 45 mm
 D-Rings : Ø 9 mm 304 Stainless Steel (EN 362)



BM-45
BOSUN'S HARNESS
 Material : Polyester 45 mm
 Size : S/M, L/XL
 Weight Approx: 547 g
 Webbing : Polyester 45 mm
 D-Rings : Ø 9 mm 304 Stainless Steel (EN 362)
 Buckle Ø 6 mm 304 Stainless Steel (EN 362)



I-451
RESCUE HARNESS
 Material : Polyester
 Size : S/M, L/XL
 Weight Approx: 877 g
 Standard : EN 12277



G-18 / G-18A
ROPE GLOVE (SAILING, CLIMBING...)
 Material : Made of Suede Leather, Aramide Patch, Stitched With Aramide Thread
 Size : S/M, L/XL



BG-05
ROPE BAG
 Material : Coated Polyester
 Size : W 35 x L 35 x H 50

ACCESSORIES



SPECIAL ROPE STAND

Display for retailing yacht ropes.
Capacity for at least 10 spools in different sizes.

MEASUREMENTS

Width : 105 cm
Carrying Rods : 100 cm
Depth : 65 cm
Height : 230 cm



LEATHER LINE THROWER

Material : Made of Black Leather Filled with Lead
Weight Approx : 400 g
Properties : Simple to Use, Effective, Safe and Reliable



KAYA WHIPPING TWINES (Ø1 - 1,2 mm)

Material : HT Waxed Polyester Fiber
Properties : Easy to Handle, High Abrasion Resistant



LUPES CORD BOX (Ø3-4 mm)

Material : HT Polyester Fiber
Properties : Easy to Handle, High Abrasion Resistant

3 mm 10x20 Meter (Mono Colours)
3 mm 10x20 Meter (With Flecks)
4 mm 10x10 Meter (Mono Colours)



HEATCUTTING DEVICE

An extremely practical tool for the cutting and sealing of Kaya Ropes



KEY HOLDER



TECHNICAL APPENDIX

OUR MATERIALS



DYNEEMA® FIBER

Dyneema®, an UHMWPE fiber, was invented by DSM over 30 years ago and has been in production since 1990. The fiber is incredibly versatile with virtually limitless applications. The fiber is manufactured by means of a gel-spinning process that combines extreme strength with incredible softness. Dyneema® is a super-strong fiber based on UHMWPE. It offers maximum strength combined with minimum weight.

Dyneema® SK75 is a high-strength, low-stretch fiber with good durability. It has been considered as the industry reference for years.

Dyneema® SK78 proved its superior performance under extreme conditions. The high modulus fiber, SK78 has the same strength as SK75 but offers significantly improved creep characteristics than its predecessor.

Dyneema® SK99 provides exceptional strength for its weight. - 99 sailing inspirations with Dyneema® spotlights and shares the many ways the world's strongest fiber is extending performance and giving professional and recreational sailors a winning, and safety, edge. SK99 has nearly 20% higher strength than SK78 and keeps the same elongation and creep features as SK78.

Dyneema® DM20 has ultra-high creep resistant and zero permanent elongation. Developed for offshore use, DM20 ropes outperform alternatives, exceeding standards for deep-water mooring and outlasting the installation's operational life. While slightly lower in tenacity than SK78, DM20's key advantage is its near-zero creep, making it ideal for static load applications like standing rigging



TECHNORA® FIBER

Technora® is a para-aramid fiber made from co-polymers and produced from poly-paraphenylene terephthalamide (PPTA).

It was independently developed by Teijin and has been commercially available since 1987. This high performance fiber has a range of excellent properties, including high tensile strength, good fatigue resistance, long-term dimensional stability and good resistance to corrosion, heat, chemicals and saltwater.



VECTRAN® FIBER

Vectran® is a high-performance multifilament yarn spun from liquid crystal polymer (LCP) produced by Kuraray in Japan.

Vectran® is currently the only melt spun LCP fiber in the world that is commercially available. The unique combination of characteristics of Vectran® fibers make it superior to many other materials and enable it to perform under conditions in which other materials fail.



TWARON® FIBER

Twaron® is a para-aramid, high-performance yarn. Offering well-balanced performance in terms of mechanical properties, chemical resistance and thermal stability, Twaron® is recognized across a wide range of industries as an extremely valuable material with excellent durability. Their experience in aramid production, which extends back more than 30 years, not only guarantees a technically well-established product, it is also the basis for developments, often in close cooperation with our customers, to tailor Twaron® to the specific requirements of various applications.

POLYESTER

POLYESTER

First commercial polyester fiber production: 1953, Dupont company. Polyester is a category of polymers which contain the ester functional group in their main chain. Polyester is the most durable of the common materials. It has good breaking load and a low elongation. It has good resistance against sunlight, external abrasion. Polyester does not lose strength rapidly due to cyclic loading. Polyester has a low co-efficient of friction. Polyester is used as a material for the cover (protection against UV radiation) in the high-tech ropes and is most widely used fiber in yachting ropes as well as for anchoring lines.

POLYAMIDE

POLYAMIDE

Commercial production of nylon fiber began in 1939 with the DuPont company. Nylon is a manufactured fiber in which the fiber-forming substance is a long-chain synthetic polyamide, where less than 85% of the amide linkages (-CO-NH-) are directly attached to two aliphatic groups. Polyamides lose strength when wet but have better abrasion resistance in wet conditions compared to dry ones. However, they can become stiff if kept wet for too long. The most important polyamides are PA 6 and PA 6.6. Polyamide is commonly used in mooring lines, sport climbing ropes, and safety and rescue ropes.

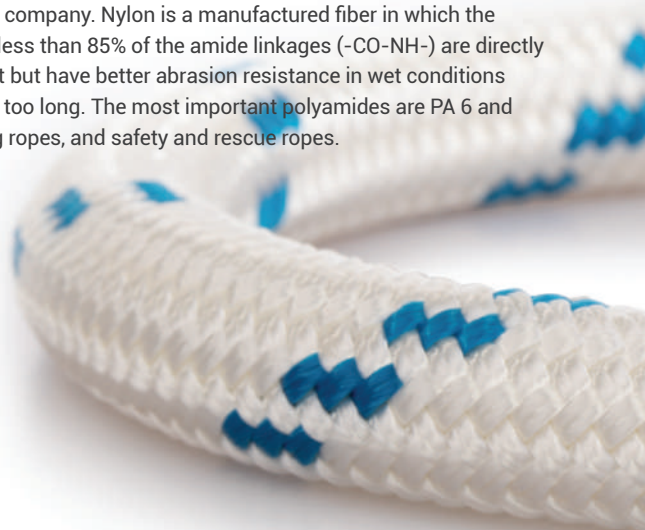

OUR TREATMENTS



This special polyurethane coating known as long lasting- most efficient kind of protective coating that is being applied to each of our high-tech lines to improve abrasion resistance on the ropes and avoids slippage between cover and core. This particular process offers excellent substrate protection to get better results, which also makes the splicing much easier.

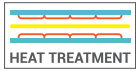

This particular thermal process increases efficiency and strength of Dyneema® ropes, which also achieves significant improvements in the break load of the rope and almost eliminates the 'creep' that helps ropes to have better performance. This procedure contracts the yarns and increases the net fiber density of the rope as well. The ropes become stronger and more durable than standard production performance ropes through these processes.



Dyneema® fiber currently has a lowest stretch among all the other synthetic fibers. However, the constructional elongation will occur during twisting and braiding processes of basic rope manufacturing procedure. Pre-Stretch method is used to minimize this constructional elongation and improve rope strength. When the heat set and Pre-Stretch process applied on the rope together, the both constructional and structural elongation will be reduced yet further increase in strength is also obtained by making the polymer to linear array. We apply this method to all of our high-tech and mid-tech lines to have an excellent product that exceeds our customer's needs.

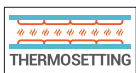

This Thermo Setting process not only extends the lifespan of the rope but also enhances its strength and flexibility, making it ideal for various applications. With its exceptional thermal performance and ability to withstand extreme conditions, Thermo Setting treated ropes offer extra durability and reliability as well as extra softness in hand, providing peace of mind to users in demanding environments.





DYNE K[®] 78/99

BENEFITS / FEATURES

- Superior Abrasion Resistance
- Excellent Breaking Load (SK99)
- Buoyant
- Durable
- Very Low Stretch
- Lightweight
- Easy to Splice
- Does not Kink

DYNE K[®] EXTREME 78/99

BENEFITS / FEATURES

- Superior Abrasion Resistance
- Superior Breaking Load (SK99)
- Buoyant
- Durable
- Extremely Low Stretch
- Lightweight
- Easy to Splice
- Does not Kink



VECT K[®]

BENEFITS / FEATURES

- No Creep Under Constant Loads
- High Breaking Load
- Extremely Low Stretch
- Ideal for Steering System
- Easy to Splice
- Perfect for Static Application
- Pu Coating for Improved Protection Against Abrasion



TECHNORA® - POLYESTER COVER (TP)

Abrasion Resistance	★★★★☆
UV Resistance	★★☆☆☆
Winch Performance	★★★★☆
Clutch & Jammer Performance	★★★★☆
Heat Resistance	★★★★☆

Technora



Vectran™

VECTRAN® - POLYESTER COVER (VP)

Abrasion Resistance	★★★★☆
UV Resistance	★★☆☆☆
Winch Performance	★★★★★
Clutch & Jammer Performance	★★☆☆☆
Heat Resistance	★★★★☆

ARAMID-POLYESTER COVER (AP)

Abrasion Resistance	★★★★☆
UV Resistance	★★☆☆☆
Winch Performance	★★★★☆
Clutch & Jammer Performance	★★★★★
Heat Resistance	★★★★☆

Twaron



DYNEEMA® - TECHNORA® COVER (DT)

Abrasion Resistance	★★★★★
UV Resistance	★★★★☆
Winch Performance	★★★★☆
Clutch & Jammer Performance	★★★★☆
Heat Resistance	★★★★☆

Technora



DYNEEMA® - POLYESTER COVER (DP)

Abrasion Resistance	★★★★★
UV Resistance	★★★★★
Winch Performance	★★☆☆☆
Clutch & Jammer Performance	★★★★☆
Heat Resistance	★★☆☆☆

WITH
Dyneema



POLYESTER COVER

Abrasion Resistance	★★★★☆
UV Resistance	★★★★★
Winch Performance	★★☆☆☆
Clutch & Jammer Performance	★★★★☆
Heat Resistance	★★☆☆☆



TYPE OF SPLICING

What is the purpose of eye splice? And Why is it so important?

Rope splicing is the forming of a semi-permanent joint between two ropes or two parts of the same rope by partly untwisting and then interweaving their strands. Splices can be used to form a stopper at the end of a line, to form a loop or an eye in a rope, or for joining two ropes together. Splices are preferred to knotted rope, since while a knot typically reduces the strength by 20–40%, a splice is capable of attaining a rope's full strength.



PILOT SPLICE

EYE SPLICE

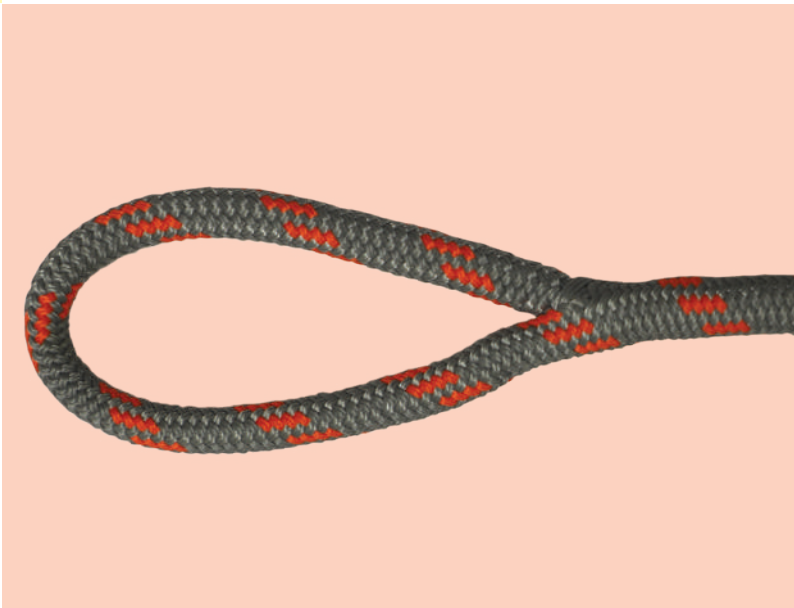

CORE SPLICE



TYPE OF SPLICING



THIMBLE EYE

EYE SPLICE

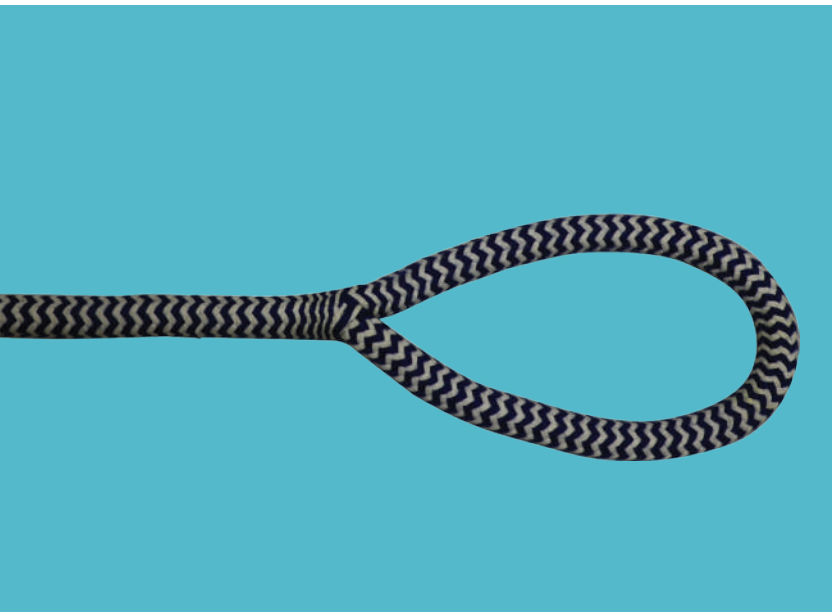

EYE SPLICE

OVERVIEW PROPERTIES

FIBERS	POLYAMIDE 6&6.6 (PA)	POLYESTER (PES)	POLYPROPYLENE MULTIFILAMENT (PP)	POLYPROPYLENE (HIGH) TENACITY (HTPP)
BRAND NAME	NYLON® PERLON® ENKALON®	DIOLEN® TREVERIA® DACRON®	HOSTALEN® SOFTLENE® LEOLENE®	LEOLENE® AROVA® BETELON®
TENACITY OF YARN (CN/DTEX)	7-9	7-9	APP.6	APP.8
SPEIFIC GRAVITY (KG/DM³)	1,14	1,38	0,91	0,91
REDUCTION IN TENACITY WHEN WET (%)	10-15	0	0	0
WATER ABSORPTION (%)	1-7	0,5-2	0	0
KNOT STABILITY (%)	60-65	55-60	55-65	55-65
UV RESISTANCE	VERY GOOD	EXCELLENT	GOOD ONLY WHEN TREAT	GOOD ONLY WHEN TREAT
BREAKING STRETCH (%)	14-28	10-18	14-17	15-16
CREEP	SLIGHT CREEP UNDER LOAD	HARDLY MEASURABLE	CREEPS AT HIGH LOADS	CREEPS AT HIGH LOADS
RESISTANCE TO ABRASION	EXCELLENT	EXCELLENT	SUFFICIENT	SUFFICIENT
WASHING TEMPERATURE (°C)	50-60	50-60	30	30
RESISTANCE TO ACIDS (%)	GOOD	GOOD	VERY GOOD	VERY GOOD
RESISTANCE TO PETROLEUM BASED PRODUCTS	EXCELLENT	EXCELLENT	EXCELLENT	EXCELLENT
RESISTANCE TO SOLVENTS	FORMIC ACID & ACETIC ACIT AT HIGH TEMPERATURE	PHENOLS, CRESOLS ZINC CHLORIDE	MINIMAL REACTION	MINIMAL REACTION
RESISTANCE TO ALKALI	GOOD RESISTANT AGANIST WEAK SOLUTIONS	GOOD AT ROOM TEMPERATURE	GOOD RESISTANT AGANIST WEAK SOLUTIONS	GOOD RESISTANT AGANIST WEAK SOLUTIONS
INSULATING PROPERTIES	VERY GOOD	VERY GOOD	EXCELLENT	EXCELLENT
HIGHEST TEMPERATURE (°C)	130	170	80	80
MELTING POINT (°C)	218	256	165	165

CHEMICAL RESISTANCE

CHEMICALS	TEST CONDITIONS			RESIDUAL STRENGTH				
	CONCENTRATION	TEMPERATURE	EXPOSURE	TYPE OF FIBRE				
	CHEMICAL TO WATER %	DEG °C	HOURS	POLYAMIDE	POLYESTER	POLYPROPYLENE	ARAMID	HMPE
ACIDS								
HYDROCHLORIC	34%	20°C	100	0%	70%	100%	95%	100%
NITRIC	66%	20°C	100	0%	100%	100%	95%	95%
SULPHURIC	96%	20°C	100	0%	100%	100%	40%	90%
FORMIC	90%	20°C	100	0%	95%	100%	90%	100%
ACETIC	100%	20°C	10	85%	95%	100%	100%	100%
ALKALIS								
CAUSTIC SODA	40%	20°C	100	50%	0%	90%	90%	100%
CAUSTIC SODA	20%	70°C	150	100%	0%	100%	85%	90%
CAUSTIC POTASH	40%	20°C	100	90%	0%	90%	90%	100%
SOLVENTS								
TRICHLOROETHYLENE	100%	30°C	150	100%	95%	80%	100%	100%
CARBON TETRACHLORIDE	100%	20°C	150	100%	100%	100%	98%	100%
BENZENE	100%	70°C	150	100%	100%	100%	98%	95%
METACRESOL	100%	100°C	40	0%	0%	100%	80%	100%
OXIDISING AGENTS								
HYDROGEN PEROXIDE	10%	20°C	100	0%	100%	90%	95%	100%

THIS TABLE SHOWS THE RESIDUAL STRENGTHS OF SYNTHETIC FIBRES AFTER CHEMICAL EXPOSURE UNDER SPECIFIC CONDITIONS.

OVERVIEW PROPERTIES

POLYETHYLENE (PE)	HIGH MODULUS POLYETHYLENE (UHMWPE)	ARAMID	LIQUID CRYSTAL POLYMER (LCP)	POLYBENZOXAZOLE (PBO)	FIBERS
	DYNEEMA® SPECTRA®	TWARON® TECHNORA® KEVLAR® HERACRON®	VECTRAN®	ZYLON®	BRAND NAME
APP. 4,5	35	20-25	20	37	TENACITY OF YARN (CN/DTEX)
0,95	0,97	1,39-1,44	1,40	1,52	SPECIFIC GRAVITY (KG/DM³)
0	0	0	0	0	REDUCTION IN TENACITY WHEN WET (%)
0	0	1,9-7	1	0,6	WATER ABSORPTION (%)
50-60	35-50	30-35	30-50	35-55	KNOT STABILITY (%)
GOOD	EXCELLENT	POOR	POOR	POOR	UV RESISTANCE
10-19	3,8	3,4	3,3	2,8	BREAKING STRETCH (%)
CREEPS AT HIGH LOADS	CREEPS AT HIGH LOAD	HARDLY MEASURABLE	IMMEASURABLE	IMMEASURABLE	CREEP
SUFFICIENT	VERY GOOD	UNSATISFACTORY	GOOD	UNSATISFACTORY	RESISTANCE TO ABRASION
30	30	80-90	60	50	WASHING TEMPERATURE (°C)
EXCELLENT	EXCELLENT	PARTIALLY GOOD RESISTANCE	EXCELLENT	GOOD	RESISTANCE TO ACIDS (%)
EXCELLENT	EXCELLENT	EXCELLENT	EXCELLENT	EXCELLENT	RESISTANCE TO PETROLEUM BASED PRODUCTS
MINIMAL REACTION	MINIMAL REACTION	MINIMAL REACTION	MINIMAL REACTION	MINIMAL REACTION	RESISTANCE TO SOLVENTS
EXCELLENT	EXCELLENT	PARTIALLY GOOD	VERY GOOD	VERY GOOD	RESISTANCE TO ALKALI
EXCELLENT	EXCELLENT	EXCELLENT	EXCELLENT	EXCELLENT	INSULATING PROPERTIES
70	70	350	200	500	HIGHEST TEMPERATURE (°C)
140	147	500 DECOMPOSES	300	650 DECOMPOSES	MELTING POINT (°C)

TYPICAL CHARACTERISTIC OF MATERIALS

MATERIALS	SPECIFIC GRAVITY	SPECIFIC MODULUS N/TEX	SPECIFIC STRENGTH N/TEX	DYNAMIC COEFFICIENT OF FRICTION AGAINST METAL	MELTING POINT °C	OTHER CHARACTERISTIC
POLYESTER	1,38	10	0,84	0,12 - 0,15	256	EXCELLENT WET INTERNAL ABRASION RESISTANCE
POLYAMIDE	1,14	4	0,84	0,10 - 0,12	218	10-15% WET STRENGTH LOSS. FAIR WET INTERNAL ABRASION RESISTANCE
POLYPROPYLENE	0,91	8	0,73	0,15 - 0,22	165	LOW STRENGTH. FLOAT ON WATER
POLYPROPYLENE/ POLYETHYLENE (MIXED POLYOLEFIN)	0,92-0,94	9	0,84	0,10 - 0,15	140	BETTER ABRASION RESISTANCE THAN POLYPROPYLENE. FLOAT ON WATER
POLYESTER/POLYOLEFIN DUAL FIBRES	0,99-1,14	10	0,80	0,10 - 0,15	256 - 140	VERY GOOD WET/DRY ABRASION RESISTANCE.
POLYAMIDE MONO AND FIBRE MIXTURE	0,98-1,14	4	0,84	0,10 - 0,12	165 - 218	GOOD ABRASION RESISTANCE FOR USE ON WINCHES
POLYESTER/POLYPROPYLENE MELT MIXTURE	0,99	8	0,80	0,12 - 0,15	173	STRONGER THAN POLYPROPYLENE. FLOAT ON WATER
ARAMID	1,44	49	2,03	0,15	500	POTENTIAL AXIAL COMPRESSION FATIGUE PROBLEMS, BUT THESE CAN BE OVERCOME. LONG TENSION-TENSION FATIGUE LIFE
LCP (LIQUID CRYSTAL POLYMER)	1,40	60	2,40	0,13	300	HIGH STRENGTH AND LOW STRETCH. LONG TERM DURABILITY TO FATIGUE
UHMWPE (HIGH MODULUS POLYETHYLENE)	0,97	110	3,50	0,07	147	LOW MELTING POINT. FLOAT ON WATER. LONG TENSION-TENSION FATIGUE LIFE
STEEL WIRE	7,85	26	0,18	0,23	1600	CORRODES. HEAVY. MODERATE TENSION-TENSION FATIGUE LIFE.

ROPE DIAMETERS TABLE FOR DOCK, TOWING & ANCHOR LINES

ROPE NAMES	POLYESTER					POLYAMIDE					POLYPROPYLENE (FLOATING)				
	LUPES® VIPERA / PREMIER	LUPES® EUROPA	LUPES® ROUND	LUPES® SQUARE	LUPES® TWIST	LUPA® VIPERA / PREMIER / USA	LUPA® EUROPA	LUPA® ROUND	LUPA® SQUARE /	LUPA® TWIST	LUPP® VIPERA / PREMIER	LUPP® ROUND	LUPP® SQUARE	LUPP® TWIST	
LENGTH OF BOAT (M)	Ø														
6	10	10	10	10	10	10	10	10	10	10	12	12	12	12	
8	10	10	10	10	10	10	10	10	10	10	12	12	12	12	
10	12	12	12	12	12	12	12	12	12	12	14	14	14	14	
12	14	14	14	14	14	14	14	14	14	14	16	16	16	16	
14	16	16	16	16	16	16	16	16	16	16	20	20	20	20	
16	18	18	18	18	18	18	18	18	18	18	22	22	22	22	
18	20	20	20	20	20	20	20	20	20	20	24	24	24	24	
20	20-22	20-22	20-22	20-22	20-22	20-22	20-22	20-22	20-22	20-22	26-28	26-28	26-28	26-28	
22	22-24	22-24	22-24	22-24	22-24	22-24	22-24	22-24	22-24	22-24	28-30	28-30	28-30	28-30	
24-28	22-24	22-24	22-24	22-24	22-24	22-24	22-24	22-24	22-24	22-24	28-30	28-30	28-30	28-30	
30-32	24-26	24-26	24-26	24-26	24-26	22-26	22-26	22-26	22-26	22-26	32-34	32-34	32-34	32-34	
34-36	26-28	26-28	26-28	26-28	26-28	26-28	26-28	26-28	26-28	26-28	34-36	34-36	34-36	34-36	
38-40	30-32	30-32	30-32	30-32	30-32	30-32	30-32	30-32	30-32	30-32	36	36	36	36	

ROPE TYPE / SAIL AREA COMPARISON TABLE

ROPE NAMES	GP ROCK D® MIX SERIES	GP ROCK V® MIX	DYNE K® / DYNE K® EXTREME	VECT K®	STORM D PRO® MIX SERIES	ROCK D® MIX	LUPES® ULTRA / TIGHT	LUPES® PLAIN / TIGHT	LUPES® LS / MIX / TIGHT	LUPES® LS WORLD	LUPES® SOFT
SAIL AREA (M²)	Ø										
10			4-5	4-5		4-5	6-8	6-8	6-8	6-8	8-10
20	6	6-8	4-5	4-5	8	6-7	8-12	8-12	8-12	8-12	10-14
30	6-8	8-10	5-8	5-8	8-10		8-14	8-14	8-14	8-14	12-16
40	6-10	10-12	6-8	6-8	8-10		10-16	10-16	10-16	10-16	12-16
50	8-10	10-12	8-10	8-10	10-12		12-16	12-16	12-16	12-16	12-16
60	8-10	10-14	8-10	8-10	10-12		12-16	12-16	12-16	12-16	12-16
70	8-10	12-16	8-12	8-12	10-14						
80	8-12	12-16	10-12	10-12	12-14						
90	10-12	14-16	10-12	10-12	12-16						
100	10-12	14-16	10-14	10-14	12-16						
125	10-14	16-20	12-14	12-14	14-18						
150	12-16	18-22	14-16	14-16	16-20						
175	12-16	18-22	14-18	14-18	18-22						
200	14-18	20-24	16-18	16-18	18-22						
225	14-18		16-20	16-20	20-24						
250	16-22		16-20	16-20	22-26						

POWER (KGF) = SAIL AREA (M²) x WIND VELOCITY²(KNOTS) x 0,02104

BREAKING FORCE (KGF) = POWER(KGF) x 5

CONVERSION TABLE

	TO CONVERT	MULTIPLY BY	TO CONVERT	MULTIPLY BY
WEIGHT	POUNDS TO GRAMS	453592	GRAMS TO POUNDS	0,002205
	POUNDS TO KILOGRAMS	0,4536	KILOGRAMS TO POUNDS	2,20462
	TONS TO KILOGRAMS	1016,05	KILOGRAMS TO TONS	0,0009842
	POUNDS TO OUNCES	16	OUNCES TO POUNDS	0,0625
	POUNDS/100 FEET TO GRAMS/METERS	14,8816394	GRAMS/METERS TO POUNDS / 100 FEET	67,0969
STRENGTH	KILOGRAMS TO KILONEWTONS	0,0098	KILONEWTONS TO KILOGRAMS	101,972
	TONS TO NEWTONS	9810	NEWTONS TO TONS	0,000102
LENGTH	INCHES TO MILIMETERS	25,40	MILIMETERS TO INCHES	0,03937
	FEET TO METERS	0,3048	METERS TO FEET	3,280
	FEET TO INCHES	12	INCHES TO FEET	0,833
	YARDS TO METERS	0,9144	METERS TO YARDS	1,0936
	YARDS TO FEET	3	FEET TO YARDS	0,3333
	MILES TO KILOMETERS	1,6093	KILOMETERS TO MILES	0,6214
	CIRC. INCHES TO DIAMETER MILIMETERS	8	DIAMETERS MILIMETERS TO CIRC. INCHES	0,125
AREA	SQUARE FEET TO SQUARE METERS	0,0929	SQUARE METERS TO SQUARE FEET	10,7639
	SQUARE YARDS TO SQUARE METERS	0,8361	SQUARE METERS TO SQUARE YARDS	1,1960
TEX-SYSTEM	DENIER	WT. IN G/9000M	TEX TO DTEX	10
	TEX	WT. IN G/1000M	DEN TO TEX	0,1111
	DTEX	WT. IN G/10.000M	CN/DTEX	GR/DEN



STANDARDS OF ROPES

EN ISO 9554	Fibre Ropes - General Specifications
EN ISO 1968	Fibre Ropes and Cordage - Vocabulary
EN ISO 2307	Fibre Ropes - Determination of Certain Physical and Mechanical Properties
EN ISO 1140	Fibre Ropes - Polyamide - 3, - 4 and - 8 Strand Ropes
EN ISO 1141	Fibre Ropes - Polyester - 3, - 4 and - 8 Strand Ropes
EN ISO 1346	Fiber Ropes - Polypropylene - 3, - 4 and - 8 Strand Ropes
EN ISO 1181	Fibre Ropes - Manila and Sisal - 3,- 4 and - 8 Strand Ropes
EN ISO 10547	Polyester Fibre Ropes - Double Braid Construction
EN ISO 10554	Polyamide Fibre Ropes - Double Braid Construction
EN ISO 10572	Mixed Polyolef in Fibre Ropes
EN ISO 10325	Fibres Ropes - High Modulus Polyethylene - 8 Strand Braided Ropes, 12 Strand Braided Ropes and Covered Ropes
ISO 10556	Fibres Ropes of Polyester/Polyolef in Dual Fibres
EN 1891	Personel Protective Equipment for The Prevention of Falls From A Height - Low Stretch Kernmantel Ropes
EN 892	Mountaineering Equipment - Dynamic Mountaineering Ropes - Safety Requirements and Test Methods
EN 564	Mountaineering Equipment - Accessory Cord - Safety Requirements and Test Methods

STANDARDS OF ROPES

MIL-DTL 24050E	Polyamide Fibre Ropes - Double Braid Construction
----------------	---

STANDARDS OF SLINGS

EN 1492-1+A1	Textile Slings - Safety - Part 1: Flat Woven Webbing Slings, Made of Man - Made Fibers for General Purpose Use
EN 1492-2+A1	Textile Slings - Safety - Part 2: Roundslings, Made of Man - Made Fibers for General Purpose Use

QUALITY - TESTING

Kaya Ropes manufactures all kinds of ropes with technical specifications that are suitable for all kind of conditions & ropes made for a specific field with international quality certifications also offering a wide range of construction type and raw materials for every field where the safety of human life and property is of prime concern.

For certain type of products, Kaya Ropes has the type approval and inspection certificates from Turk Loydu. Additionally, Kaya Ropes offers inspection certificates from DNV and Bureau Veritas upon special request from their clients.







AUGUST HERZOG
Maschinenfabrik Gmbh & Co.Kg
AM Alexanderhaus 160 26127
Oldenburg Germany
Phone: +49 (0)441 3008 0
Fax: +49 (0)441 3008 100
E-mail: info@herzog-online.com
www.herzog-online.com



GALAN TEXTILE MACHINERY S.L.
Francesc Oller, 91 E-08225
Terrassa (Barcelona) Spain
Phone: +34 93 733 65 50
Fax: +34 93 788 40 40
E-mail: galan@galan.es
www.galan.es



TWISTEC TECHNOLOGY
Ctra. de Rubi, km 22. E-08228
Terrassa (Barcelona) Spain
Phone: +34 937 894 100
Fax: +34 937 894 355
E-mail: info@twistec.com
www.twistec.com



ROBCO ENGINEERING A/S
Kjeldgaardsvej 6
9300 Saaby Denmark
Phone: +45 98 46 40 00
Fax: +45 98 46 18 00
E-mail: info@robco-eng.com
www.robco-eng.com



SIMA GROUP
Via Chiesaccia, 2 40056
Crespellano (BO) Italy
Phone: +39 0516505511
Fax: +39 051739588
E-mail: simagroup@simagroup.it
www.simagroup.it



ZWICK GMBH & CO. KG
August-Nagel-Str. 11 D-89079
Ulm Germany
Phone: +49 (0)7305 10 0
Fax: +49 (0)7305 10 200
E-mail: info@zwick.de
www.zwick.de



AVIENT PROTECTIVE MATERIALS B.V.
Avient Center Court, Brightlands Chemelot
Campus, Urmonderbaan 22, 6167 RD Geleen
Geleen, Netherlands
Phone: +31 46 750 6590
www.avient.com



TEIJIN ARAMID B.V.
Velperweg 76 P.O. Box 5153
6802 ED Arnhem The Netherlands
Phone: +31 0 88 26 89 159
Fax: +31 0 88 26 89 179
E-mail: ropes_cables@teijinaramid.com
www.teijinaramid.com



NEXIS FIBERS AG
Gerliswilstrasse 17 6021
Emmenbrücke Switzerland
Phone: +41 (0)41 267 80 53
Fax: +41 (0)41 267 92 16
www.nexisfibers.com



I-COATS N.V.
I-Coats N.V. K. Mercierlei 29
2600 Berchem Belgium
Phone: +32 3 281 73 03
Fax: +32 3 281 73 04
E-mail: kvg@i-coats.be
www.i-coats.be

KAYA HALAT AŞ

Yönetim ve Üretim Merkezi
Management & Production Center

Gebze Organize Sanayi Bölgesi,
1000. Sokak No: 1015
Çayırova, Kocaeli, Turkey
kayagrubu.com.tr

Santral/Central
T: +90 262 677 19 19 pbx
F: +90 262 677 19 10







KAYA ROPES

Gebze Organize Sanayi Bölgesi,
1000. Sokak No: 1015
Çayırova, Kocaeli, Turkey
T: +90 262 677 19 03 pbx
F: +90 262 677 19 01
info@kayaropes.com
kayaropes.com

KAYA ROPES USA Kaya USA LLC

6453 West Rogers Circle C7
Boca Raton, FL 33487, USA
T: +1 561-303-5763
info@kayausa.us
kayaropes.com/en-US/

 /KayaRopes
 /in/kayaropes
 /KayaRopes
 /KayaRopes